

EDITION / VERSİYON  
12/2010



## TRAILER PROFILES

*TIR PROFİLLERİ*

 **Lorenzoline**<sup>®</sup>  
aluminium profile system

## company information

The company started its work life with copper and lead casting in the 1960s and in the 1980s we started to serve in The Aluminium Sector with a 1200 ton capacity aluminium extrusion press.

KURTOĞLU Aluminium is located in Çorlu, approximately 100 km faraway from Istanbul and it operates in 22.000 m2 closed, 11.000 m2 open area.

According to our latest investments the company has become a full modern integrated aluminium extrusion company;

- Increasing its annual production capacity to ~ 34.000 tons,
- Working with ~ 400 qualified employers,
- Using the ISO 9001:2000 Management System.

The company's main production features are described as below:

- Tool Building,
- Aluminium Extrusion Presses, (800 ton , 1460 ton, 1880 ton, 1880 ton , 2100 ton and 2700 ton),
- Anodized Facilities (According to Qualanod Standards), Capacity 91.000 A.
- Powder Coating Facilities (According to Qualicoat Standards),
- Mechanical (CNC Applications) Treatments.

Kurtoglu Aluminium export its products to Switzerland, Germany, Austria, Greece, Cyprus, Bulgaria, Russian Federation, Ukraine, Lithuania, Moldavia, Serbia, Montenegro, Hungary, Iran, Iraq, Armenian, Kazakhstan, Macedonia, Albanian, Romania, Georgian. Using the ISO 9001:2000 Management System as a base Kurtoglu Aluminium continue the drive towards zero defect for all customers.

## firmamız hakkında

Şirketimiz 1960' lı yıllarda Bakır ve Kurşun ile üretim hayatına başlamıştır. 1980 yılında 1200 tonluk Alüminyum Ekstrüzyon presi ile üretim sektörüne girmiştir.

KURTOĞLU Alüminyum İstanbul'a yaklaşık 100 km mesafede Çorlu'da bulunmaktadır. 22.000 m2 kapalı 11.000 m2 açık alanda faaliyetini sürdürmektedir. Son yapılan yatırımlarla şirketimiz modern bir entegre tesise haline ulaşmıştır.

Şirketimizin ana özellikleri aşağıda da belirtilmiştir:

- Yıllık kapasite ~ 34.000 ton,
- Yaklaşık ~ 400 kalifiye eleman,
- ISO 9001:2000 kalite sistemi,
- Qualicoat Belgesi,
- Qualanod Belgesi,
- CE Belgesi,
- Kalıphane Bölümü (Tel erozyon, İşleme Merkezi)
- Alüminyum Ekstrüzyon Presleri; (800 ton, 1460 ton, 1880 ton, 1880 ton ve 2600 ton),
- Eloksal Tesisi (91.000 Amper)
- Elektrostatik Toz Boya Tesisi
- Mekanik İşlem Bölümü ( CNC İşleme Merkezi)

KURTOĞLU Alüminyum ürünleri; İsviçre, Almanya, Avusturya, Yunanistan, Kıbrıs, Bulgaristan, Rusya Federasyonu, Ukrayna, Litvanya, Moldova, Sırbistan, Karadağ, Macaristan, İran, Irak, Ermenistan, Makedonya, Arnavutluk, Romanya ve Gürcistan'a ihraç edilmektedir.

KURTOĞLU ALÜMİNYUM müşterilerine sıfır hata ile hizmet vermeyi temel olarak çalışmalarını sürdürmektedir.

## quality policy

The company's quality policy is based upon the pillars of product quality, state-of-the-art technology, customer satisfaction, training, environmental concerns, and continuous development. Kurtoglu always implements this policy in all of its operations and units.

## kalite politikası

Şirketin kalite politikası ürün kalitesine, yeni teknolojilere , müşteri memnuniyetine , eğitime , çevre duyarlılığına ve sürekli gelişime dayanır.

Kurtoglu, her zaman tüm faaliyet ve birimlerinde bu politikayı uygular.



**tırprofilleri**

**truckprofiles**

tırprofilleri / truckprofiles

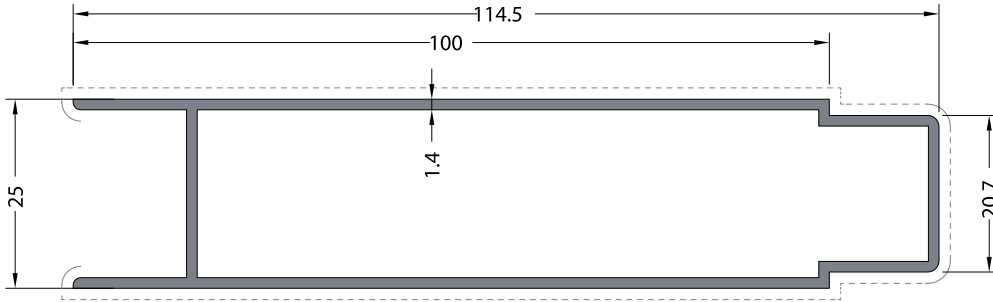

**CODE / KOD**    **THEORETICAL WEIGHT kg/m**  
**901**            *TEORİK AĞIRLIK kg/m*  
**1.033**

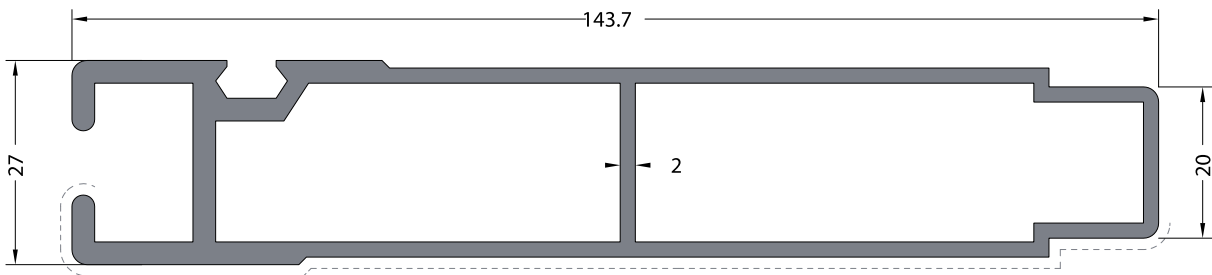

**CODE / KOD**    **THEORETICAL WEIGHT kg/m**  
**902**            *TEORİK AĞIRLIK kg/m*  
**2.277**

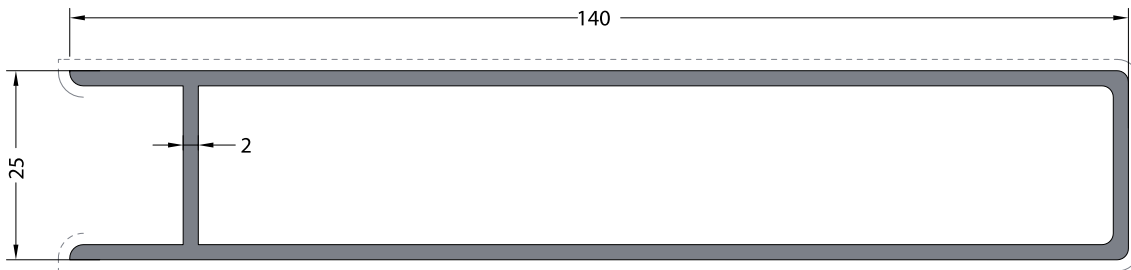

**CODE / KOD**    **THEORETICAL WEIGHT kg/m**  
**903**            *TEORİK AĞIRLIK kg/m*  
**1.741**

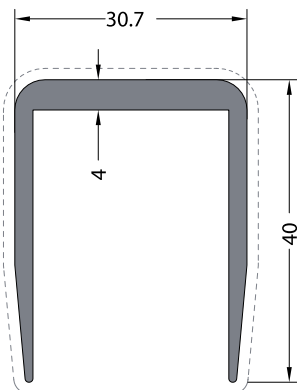

**CODE / KOD**  
**904**  
**THEORETICAL WEIGHT kg/m**  
*TEORİK AĞIRLIK kg/m*  
**0.711**

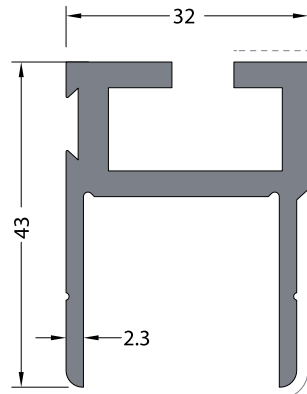

**CODE / KOD**  
**906**  
**THEORETICAL WEIGHT kg/m**  
*TEORİK AĞIRLIK kg/m*  
**1.050**

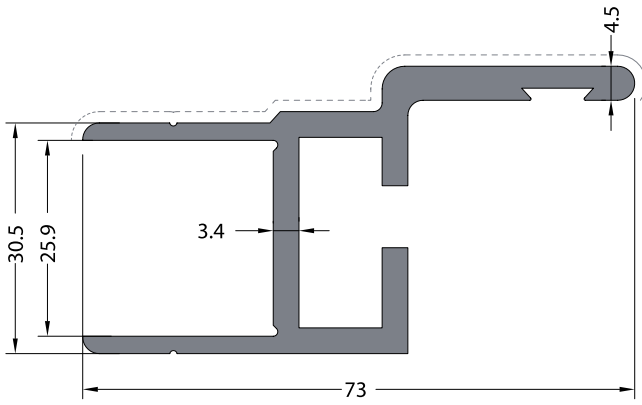

**CODE / KOD**    **THEORETICAL WEIGHT kg/m**  
**905**            *TEORİK AĞIRLIK kg/m*  
**1.398**

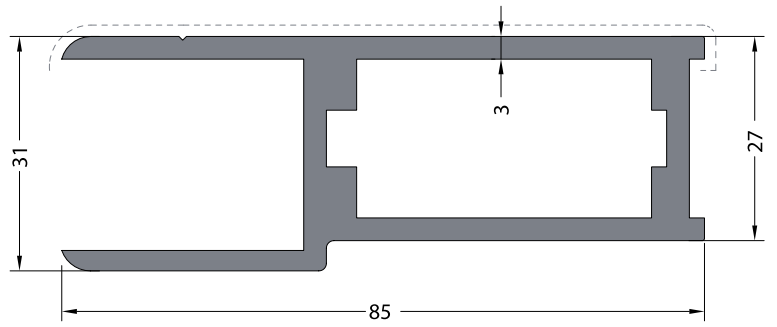

**CODE / KOD**    **THEORETICAL WEIGHT kg/m**  
**909**            *TEORİK AĞIRLIK kg/m*  
**1.933**

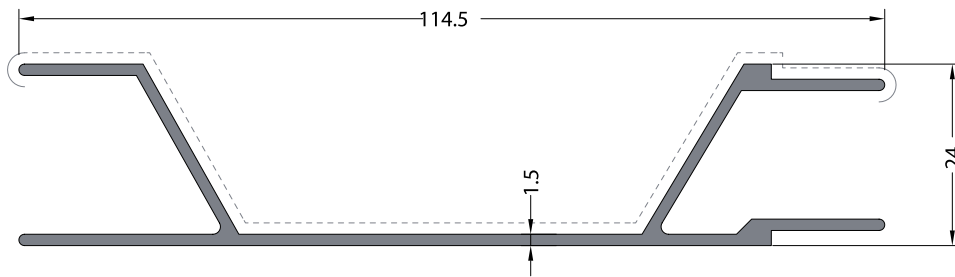

**CODE / KOD**    **THEORETICAL WEIGHT kg/m**  
**907**            *TEORİK AĞIRLIK kg/m*  
**0.848**

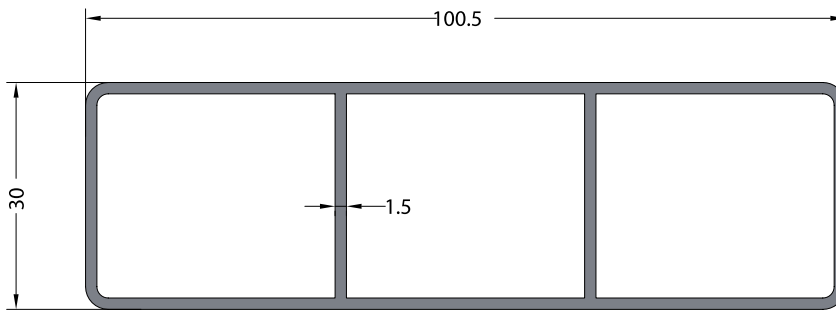

**CODE / KOD**    **THEORETICAL WEIGHT kg/m**    koruyucueloksal / protectiveanodized  
**908**            *TEORİK AĞIRLIK kg/m*  
**1.240**

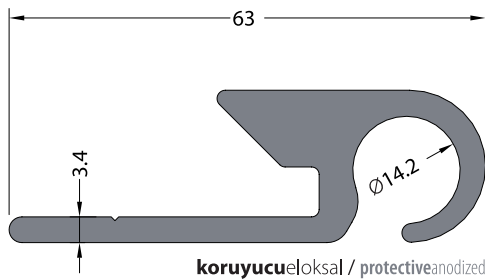

**CODE / KOD**    **THEORETICAL WEIGHT kg/m**  
**910**            *TEORİK AĞIRLIK kg/m*  
**1.223**

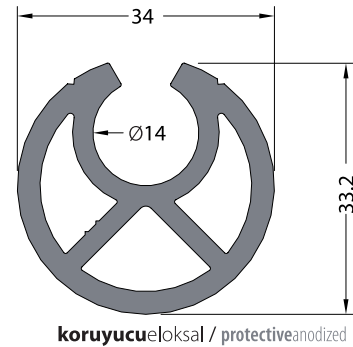

**CODE / KOD**    **THEORETICAL WEIGHT kg/m**  
**911**            *TEORİK AĞIRLIK kg/m*  
**1.166**

## tırprofilleri / truckprofiles

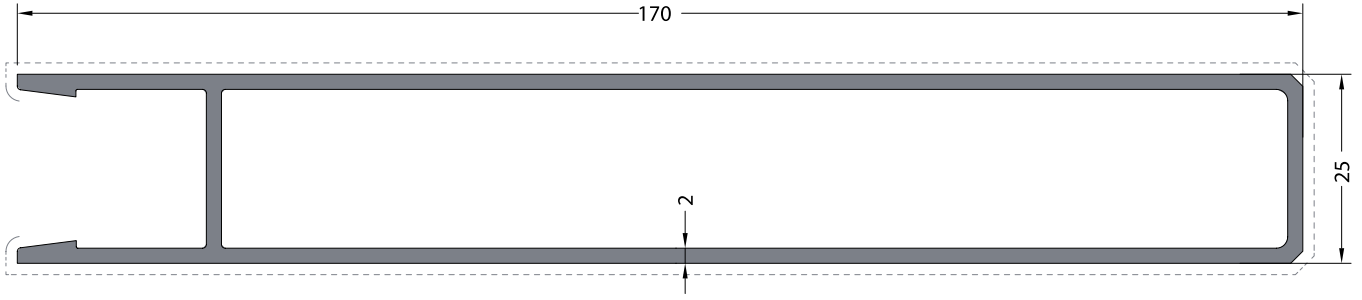

**CODE / KOD**    **THEORETICAL WEIGHT kg/m**  
**912**            *TEORİK AĞIRLIK kg/m*  
**2.088**

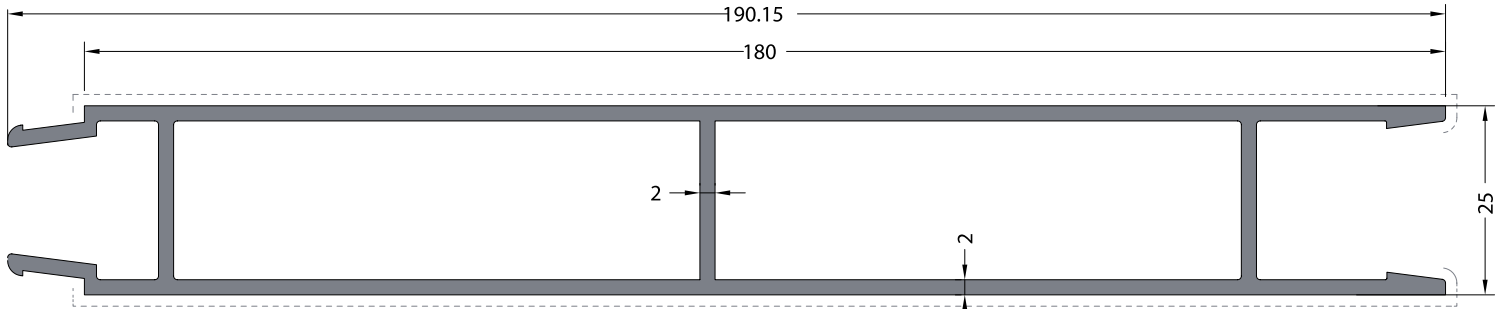

**CODE / KOD**    **THEORETICAL WEIGHT kg/m**  
**913**            *TEORİK AĞIRLIK kg/m*  
**2.448**

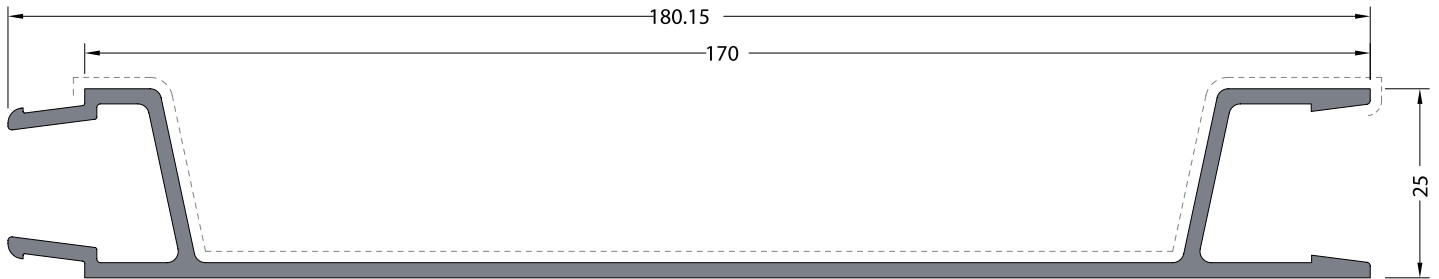

**CODE / KOD**    **THEORETICAL WEIGHT kg/m**  
**914**            *TEORİK AĞIRLIK kg/m*  
**1.478**

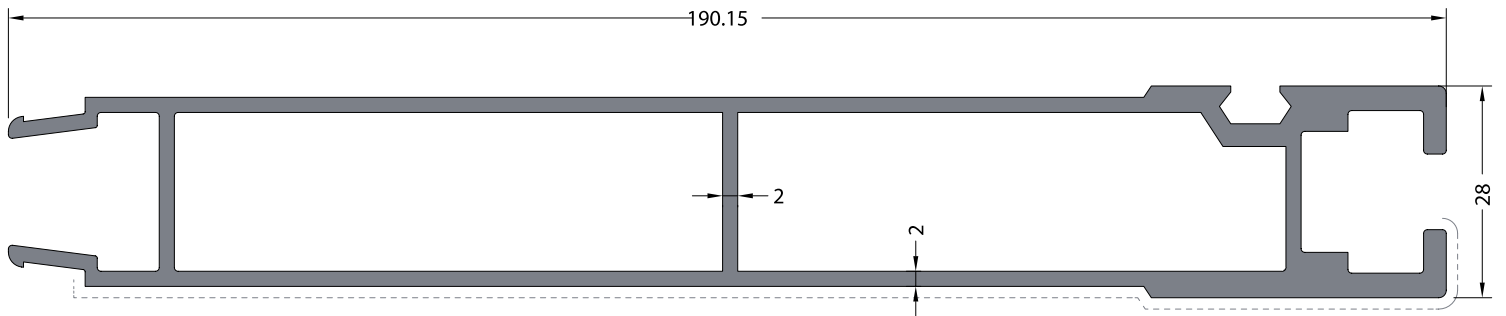

**CODE / KOD**    **THEORETICAL WEIGHT kg/m**  
**915**            *TEORİK AĞIRLIK kg/m*  
**2.921**

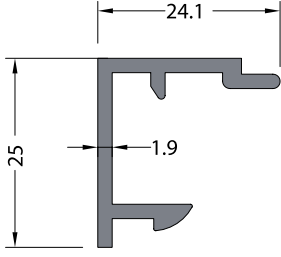

görünenüzeyyoktur / novisiblesurface

**CODE / KOD** THEORETICAL WEIGHT kg/m  
**916** TEORİK AĞIRLIK kg/m  
**0.334**

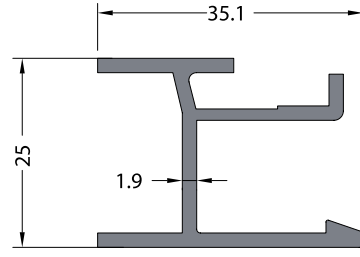

görünenüzeyyoktur / novisiblesurface

**CODE / KOD** THEORETICAL WEIGHT kg/m  
**917** TEORİK AĞIRLIK kg/m  
**0.505**

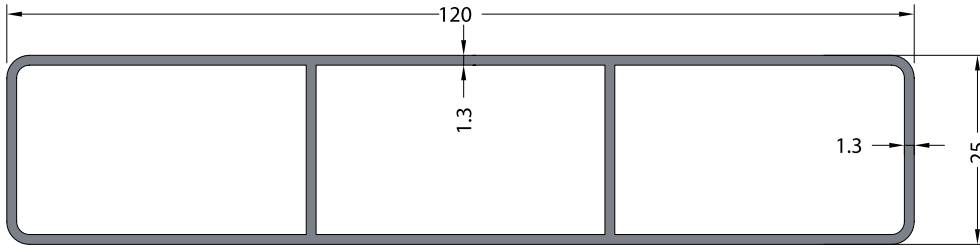

**CODE / KOD** THEORETICAL WEIGHT kg/m  
**918** TEORİK AĞIRLIK kg/m  
**1.147**

koruyucueloksal / protectiveanodized

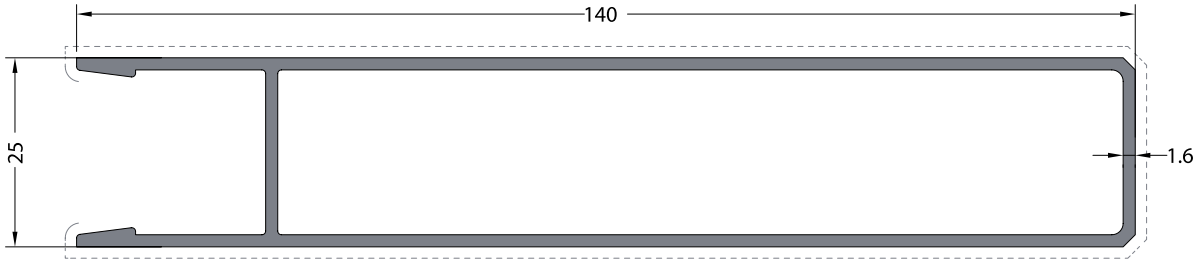

**CODE / KOD** THEORETICAL WEIGHT kg/m  
**919** TEORİK AĞIRLIK kg/m  
**1.418**

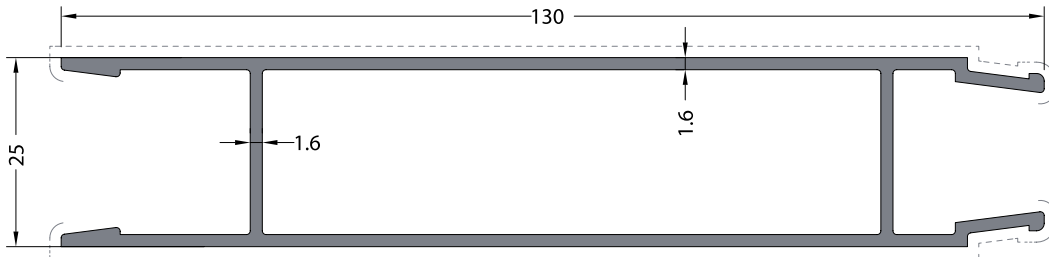

**CODE / KOD** THEORETICAL WEIGHT kg/m  
**920** TEORİK AĞIRLIK kg/m  
**1.361**

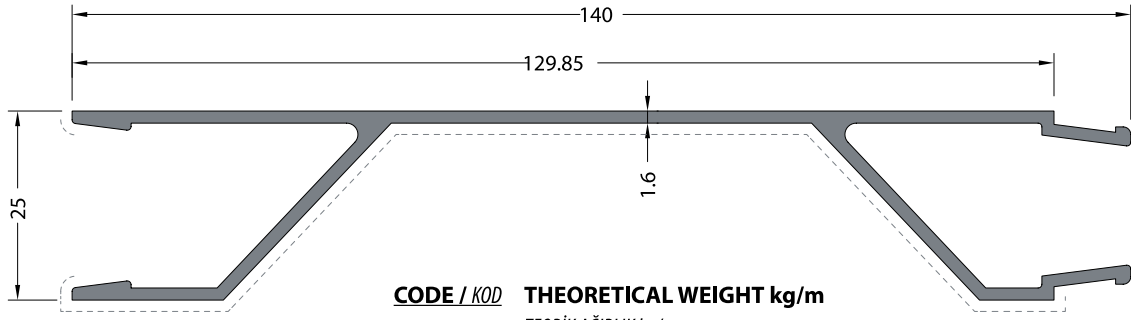

**CODE / KOD** THEORETICAL WEIGHT kg/m  
**921** TEORİK AĞIRLIK kg/m  
**1.126**

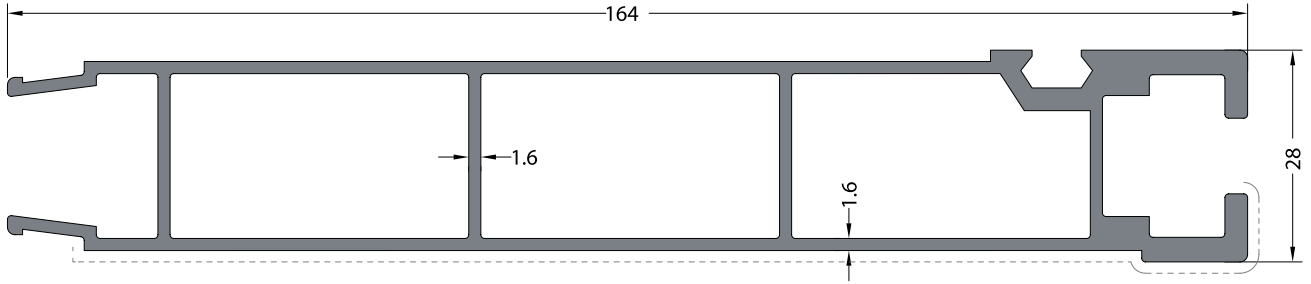

**CODE / KOD** THEORETICAL WEIGHT kg/m  
**922** TEORİK AĞIRLIK kg/m  
**2.253**

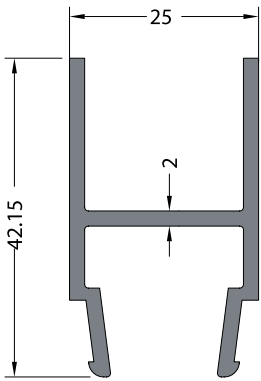

**görünen yüzey yoktur / no visible surface**

**CODE / KOD** THEORETICAL WEIGHT kg/m  
**923** TEORİK AĞIRLIK kg/m  
**0.594**

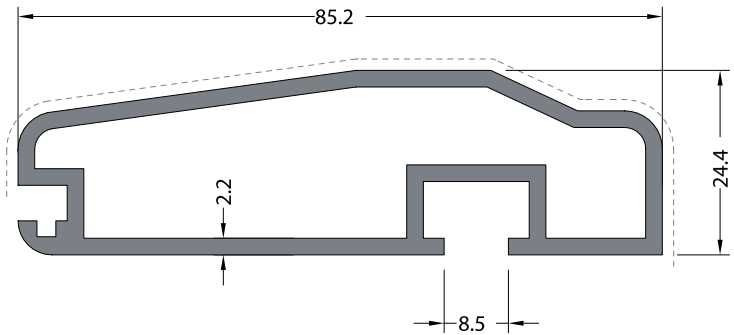

**CODE / KOD** THEORETICAL WEIGHT kg/m  
**924** TEORİK AĞIRLIK kg/m  
**1.381**



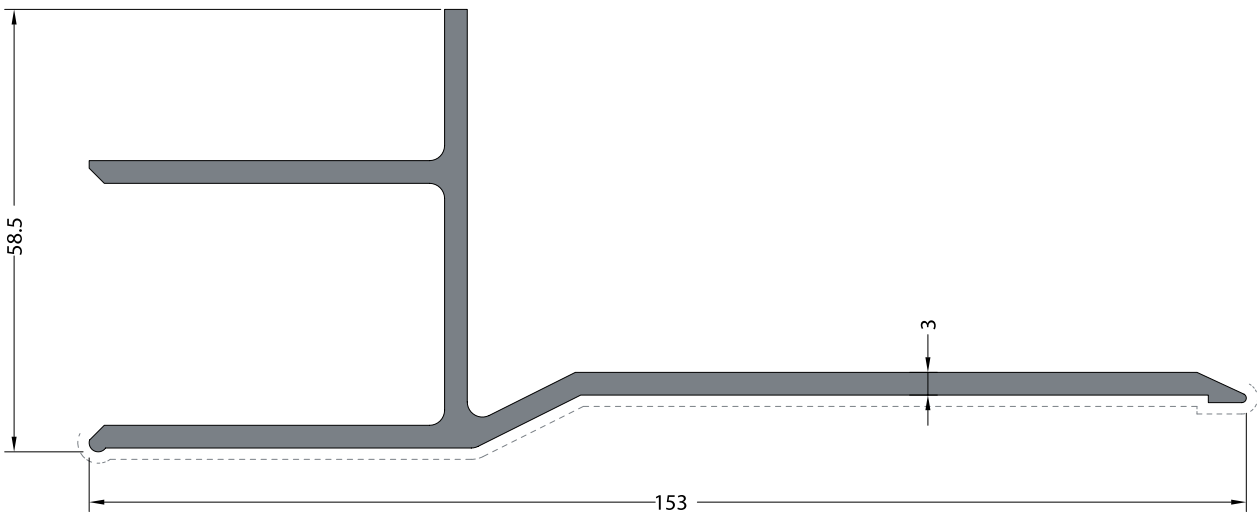

**CODE / KOD** THEORETICAL WEIGHT kg/m  
**925** TEORİK AĞIRLIK kg/m  
**2.077**

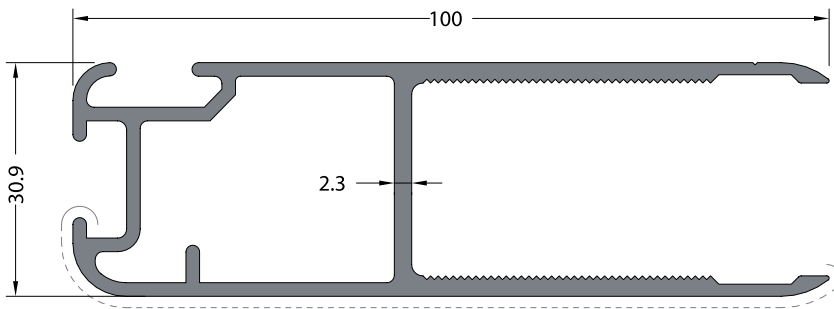

**CODE / KOD** THEORETICAL WEIGHT kg/m  
**926** TEORİK AĞIRLIK kg/m  
**1.533**

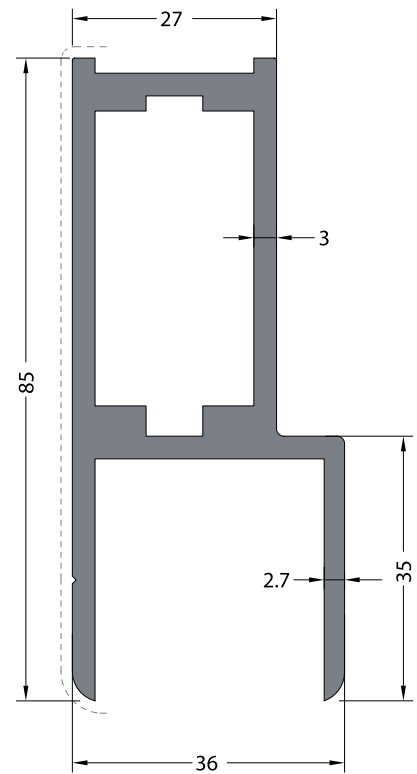

**CODE / KOD**  
**927**  
**THEORETICAL WEIGHT kg/m**  
 TEORİK AĞIRLIK kg/m  
**1.974**

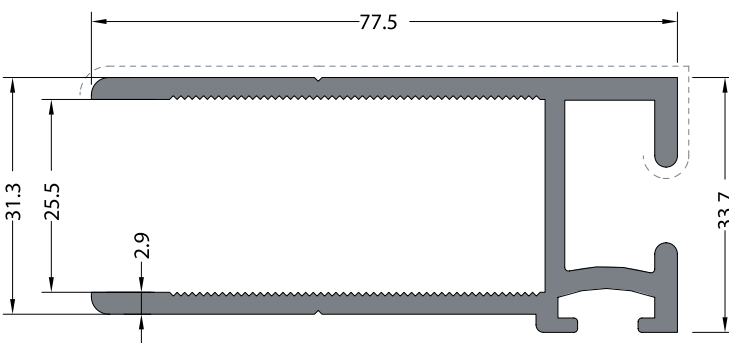

**CODE / KOD** THEORETICAL WEIGHT kg/m  
**937** TEORİK AĞIRLIK kg/m  
**1.506**

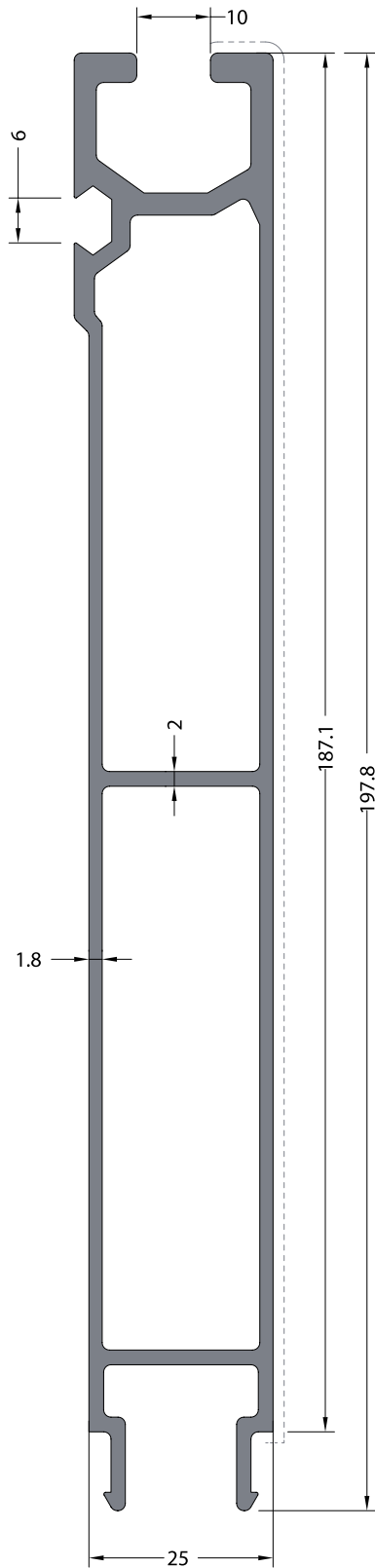

**CODE / KOD**

**938**

**THEORETICAL WEIGHT kg/m**

*TEORİK AĞIRLIK kg/m*

**2.724**

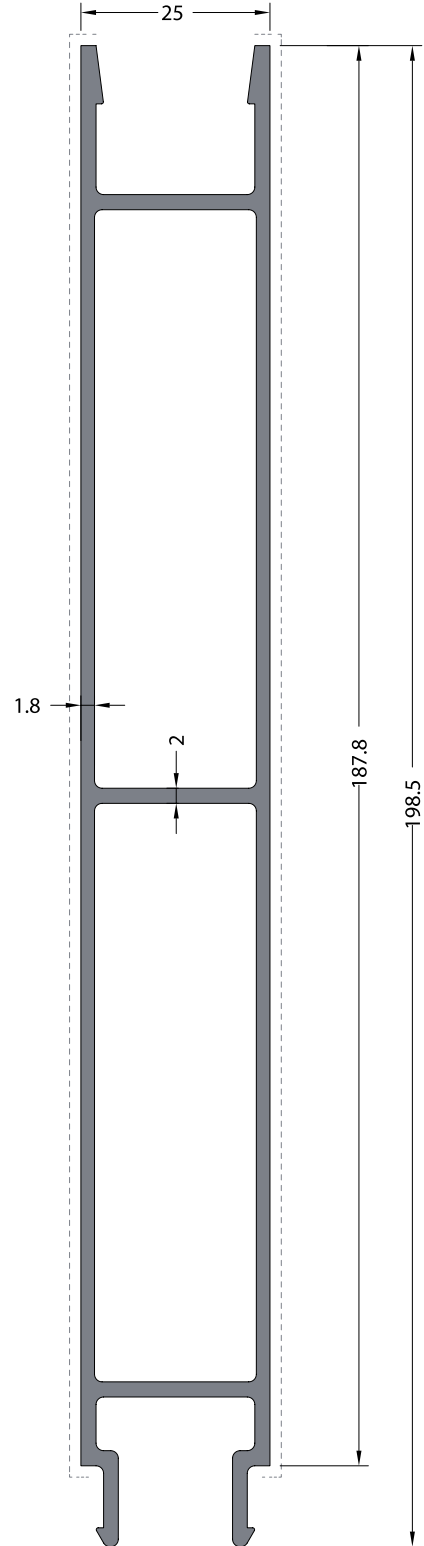

**CODE / KOD**

**939**

**THEORETICAL WEIGHT kg/m**

*TEORİK AĞIRLIK kg/m*

**2.389**

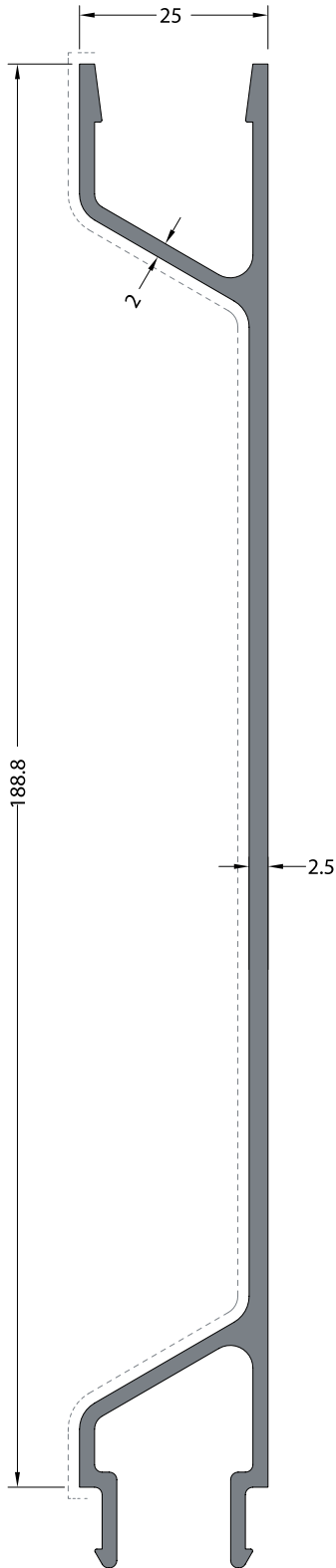

**CODE / KOD** **THEORETICAL WEIGHT kg/m**  
**940** *TEORİK AĞIRLIK kg/m*  
**1.845**

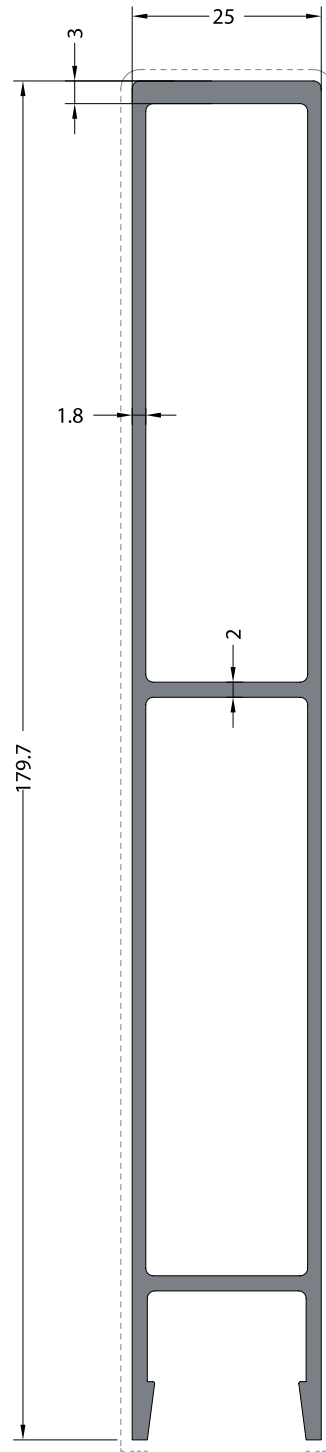

**CODE / KOD** **THEORETICAL WEIGHT kg/m**  
**941** *TEORİK AĞIRLIK kg/m*  
**2.206**

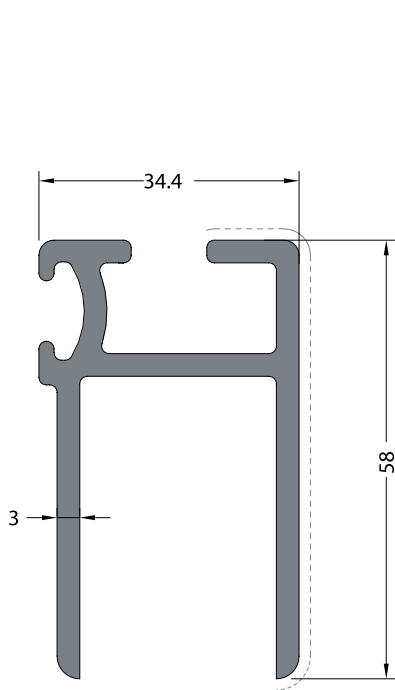

**CODE / KOD** THEORETICAL WEIGHT kg/m  
**942** TEORİK AĞIRLIK kg/m  
**1.337**

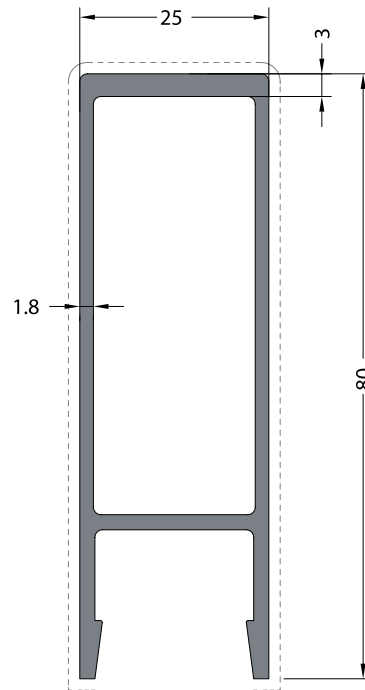

**CODE / KOD** THEORETICAL WEIGHT kg/m  
**943** TEORİK AĞIRLIK kg/m  
**1.115**

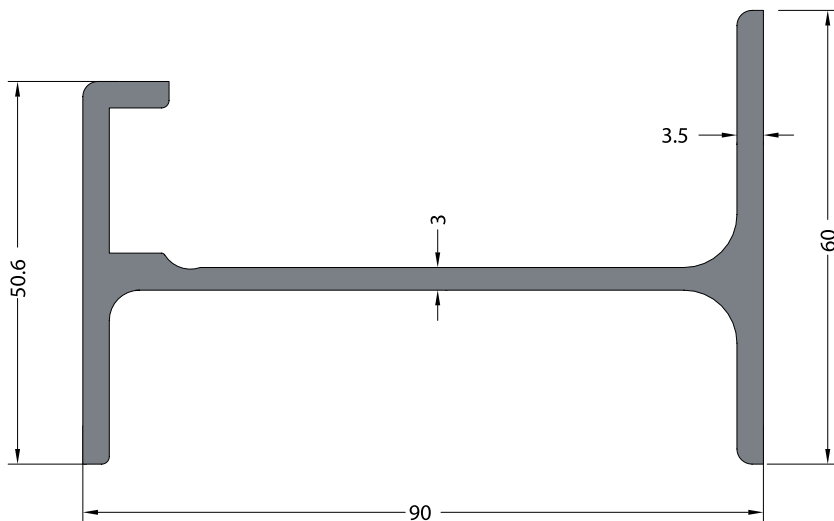

**CODE / KOD** THEORETICAL WEIGHT kg/m  
**944** TEORİK AĞIRLIK kg/m  
**1.897**

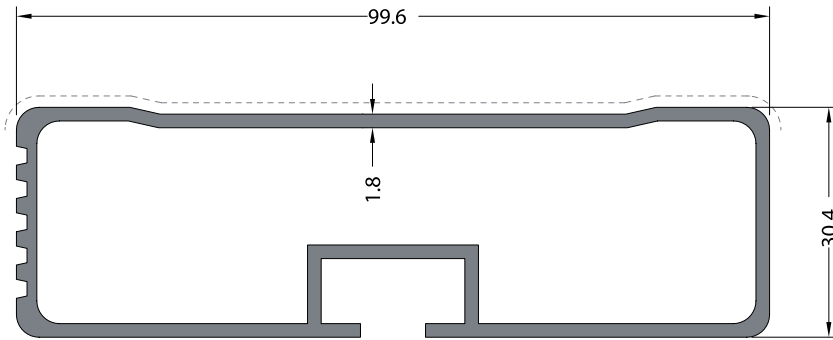
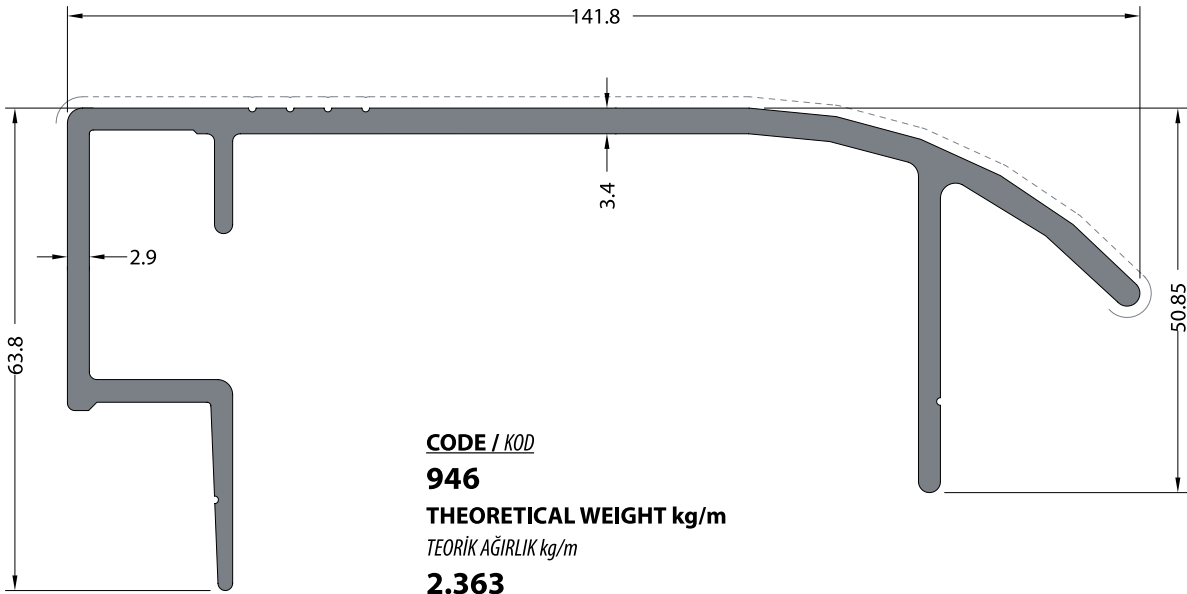

**CODE / KOD**  
**946**  
**THEORETICAL WEIGHT kg/m**  
*TEORİK AĞIRLIK kg/m*  
**1.410**

**CODE / KOD**  
**947**  
**THEORETICAL WEIGHT kg/m**  
*TEORİK AĞIRLIK kg/m*  
**1.411**

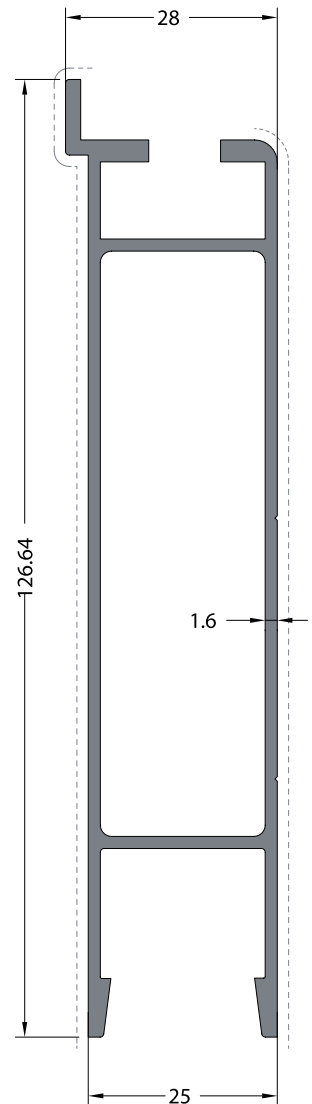

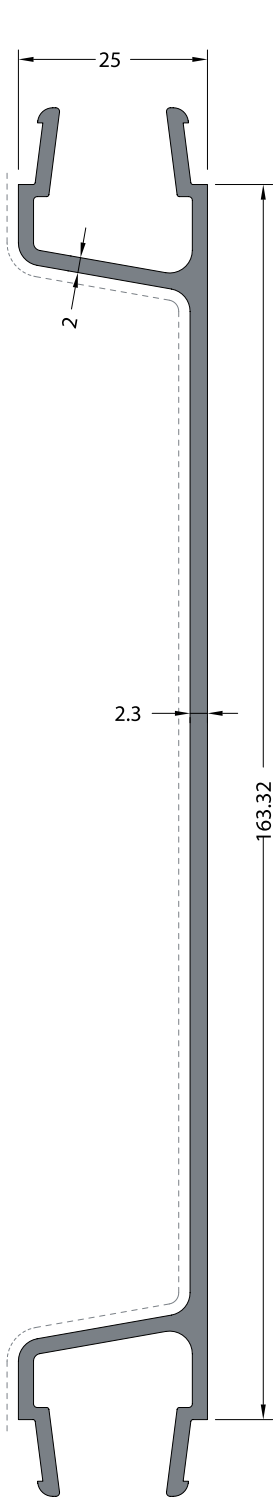

**CODE / KOD**  
**948**  
**THEORETICAL WEIGHT kg/m**  
*TEORİK AĞIRLIK kg/m*  
**1.622**

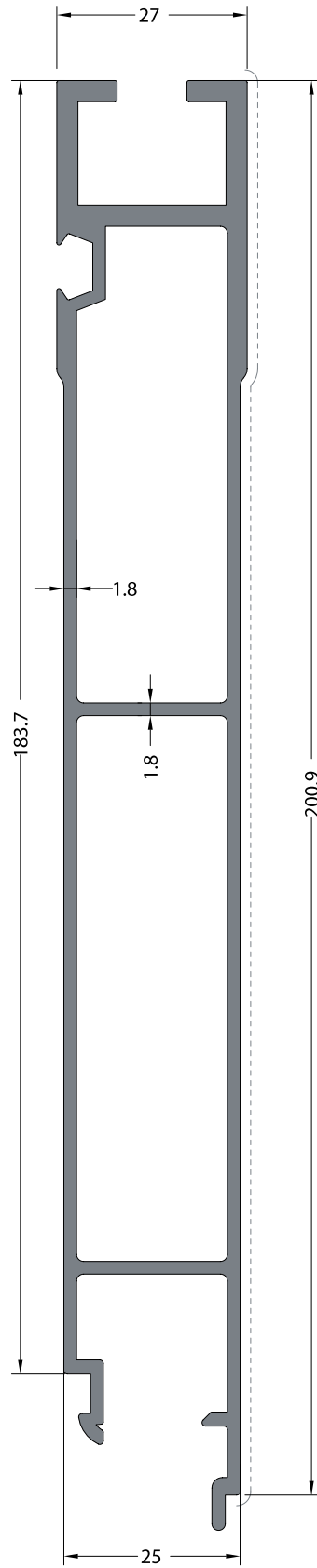

**CODE / KOD**  
**950**  
**THEORETICAL WEIGHT kg/m**  
*TEORİK AĞIRLIK kg/m*  
**2.750**

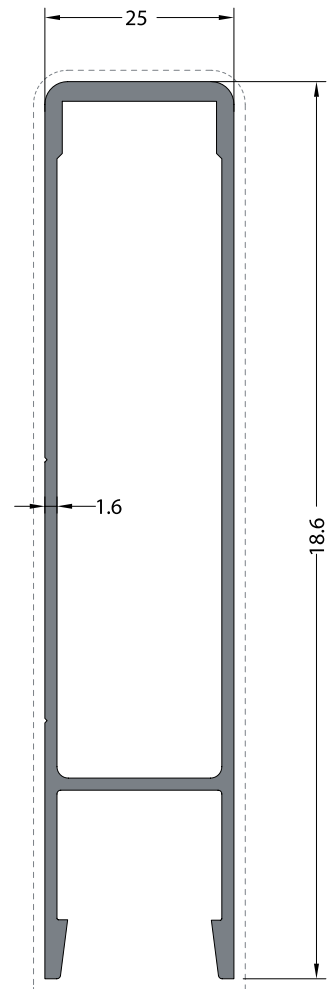

**CODE / KOD**  
**949**  
**THEORETICAL WEIGHT kg/m**  
*TEORİK AĞIRLIK kg/m*  
**1.334**

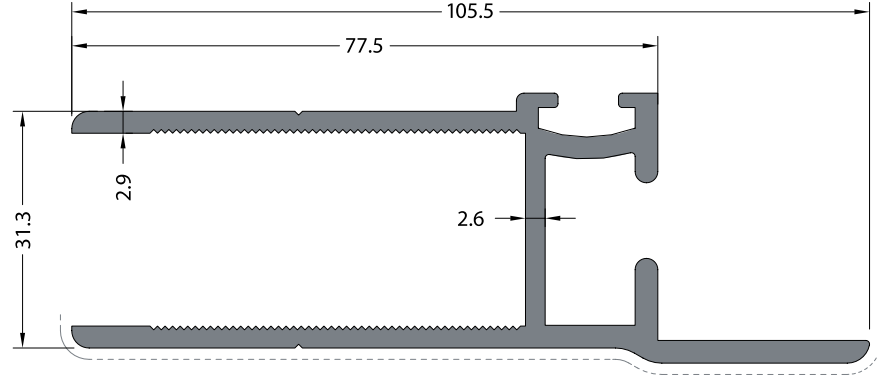

**CODE / KOD** THEORETICAL WEIGHT kg/m  
**951** TEORİK AĞIRLIK kg/m  
**1.742**

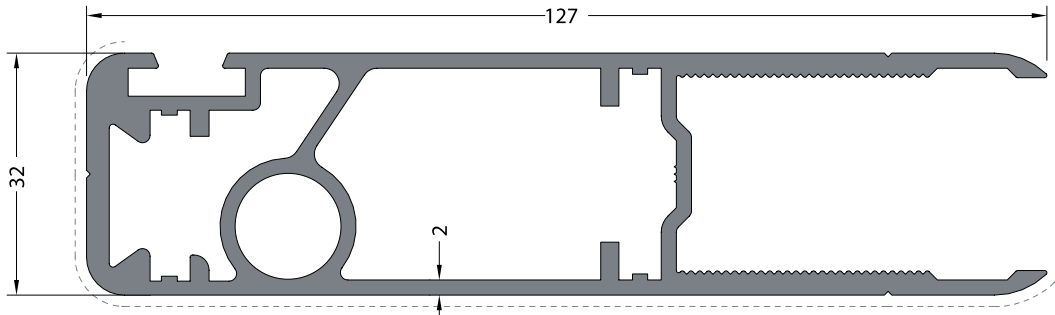

**CODE / KOD** THEORETICAL WEIGHT kg/m  
**952** TEORİK AĞIRLIK kg/m  
**2.550**

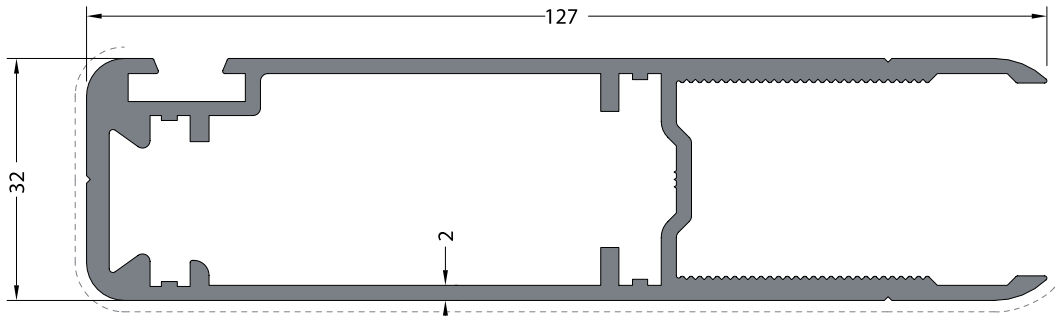

**CODE / KOD** THEORETICAL WEIGHT kg/m  
**953** TEORİK AĞIRLIK kg/m  
**2.229**

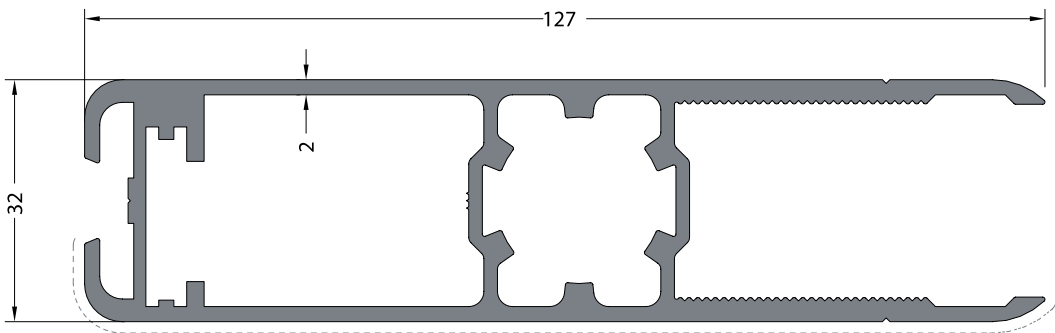

**CODE / KOD** THEORETICAL WEIGHT kg/m  
**954** TEORİK AĞIRLIK kg/m  
**2.406**

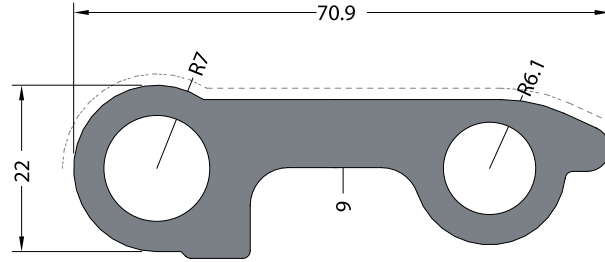

**CODE / KOD** **THEORETICAL WEIGHT kg/m**  
**955** *TEORİK AĞIRLIK kg/m*  
**2.054**

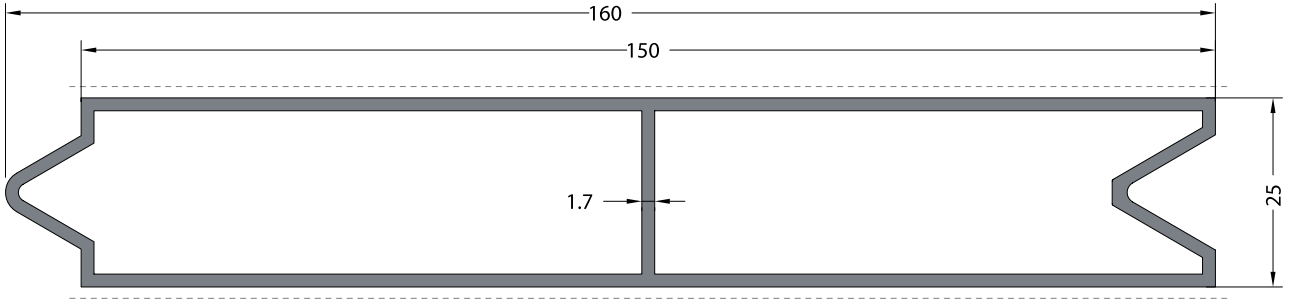

**CODE / KOD** **THEORETICAL WEIGHT kg/m**  
**958** *TEORİK AĞIRLIK kg/m*  
**1.797**



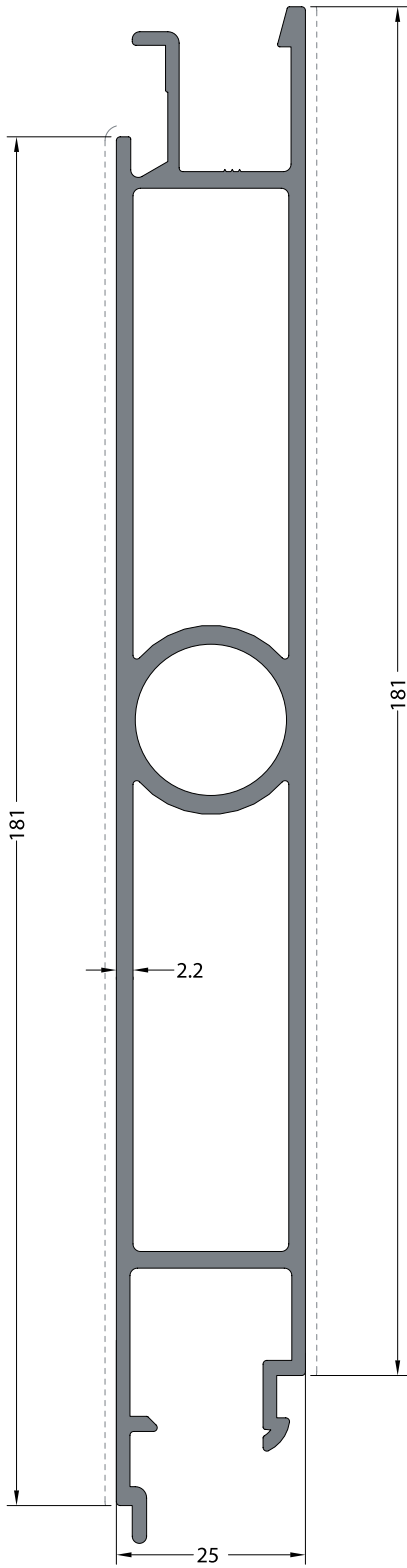

**CODE / KOD** THEORETICAL WEIGHT kg/m  
**956** TEORİK AĞIRLIK kg/m  
**2.957**

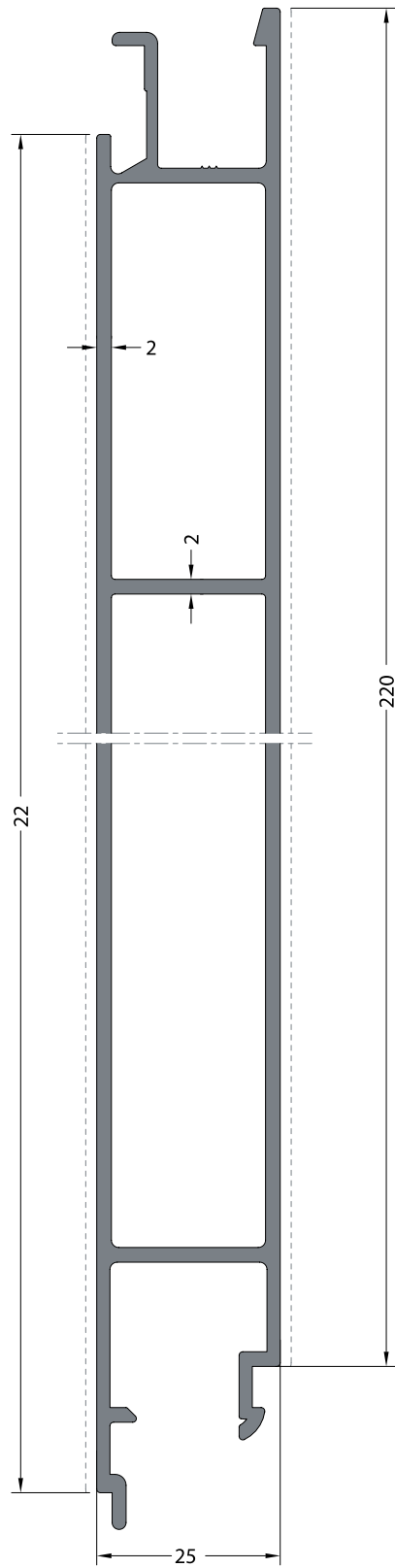

**CODE / KOD** THEORETICAL WEIGHT kg/m  
**957** TEORİK AĞIRLIK kg/m  
**2.950**

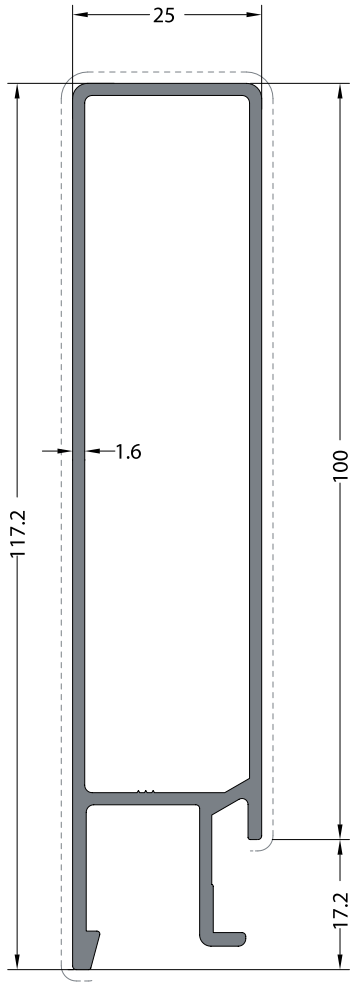

**CODE / KOD**

**959**

**THEORETICAL  
WEIGHT kg/m**

*TEORİK AĞIRLIK kg/m*

**1.273**

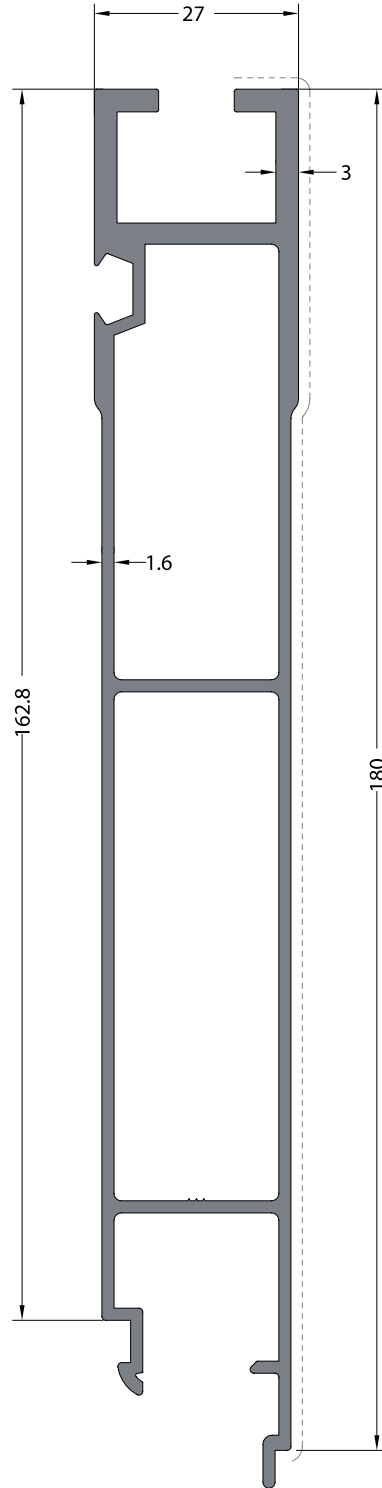

**CODE / KOD**

**960**

**THEORETICAL  
WEIGHT kg/m**

*TEORİK AĞIRLIK kg/m*

**2.332**

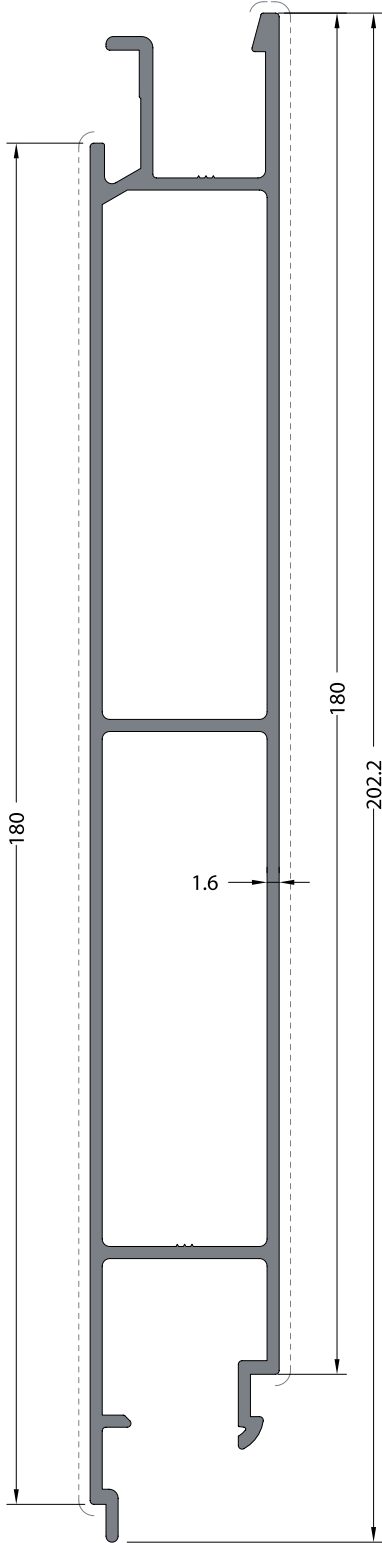

**CODE / KOD**

**961**

**THEORETICAL  
WEIGHT kg/m**

*TEORİK AĞIRLIK kg/m*

**2.114**

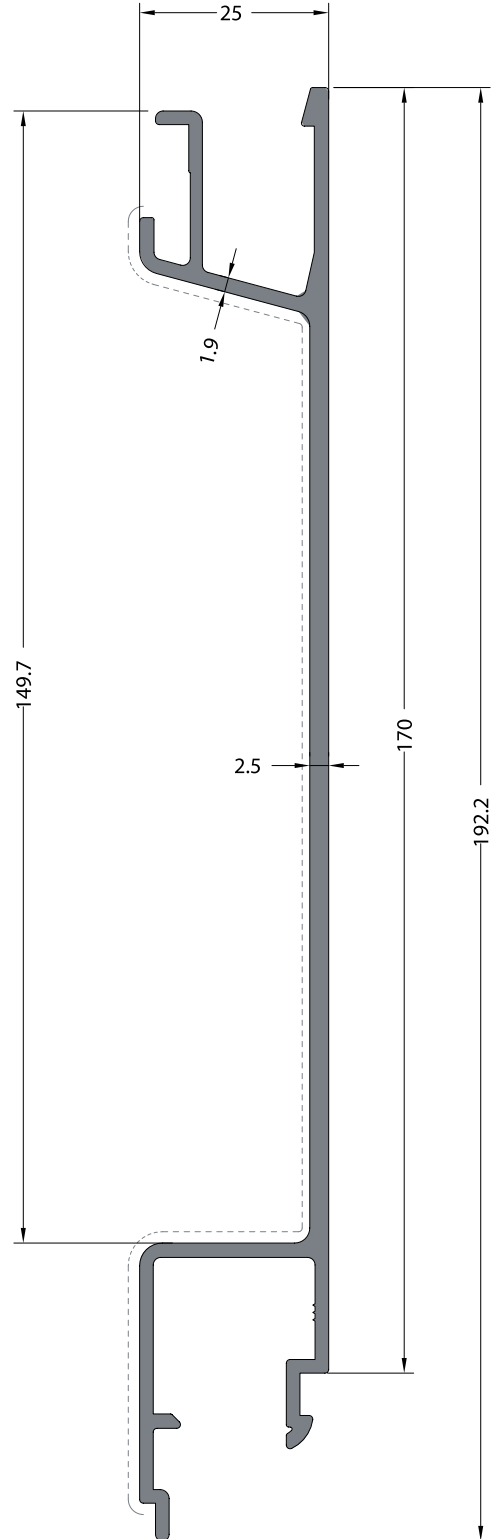

**CODE / KOD**

**962**

**THEORETICAL  
WEIGHT kg/m**

*TEORİK AĞIRLIK kg/m*

**1.763**

tırprofilleri / truckprofiles

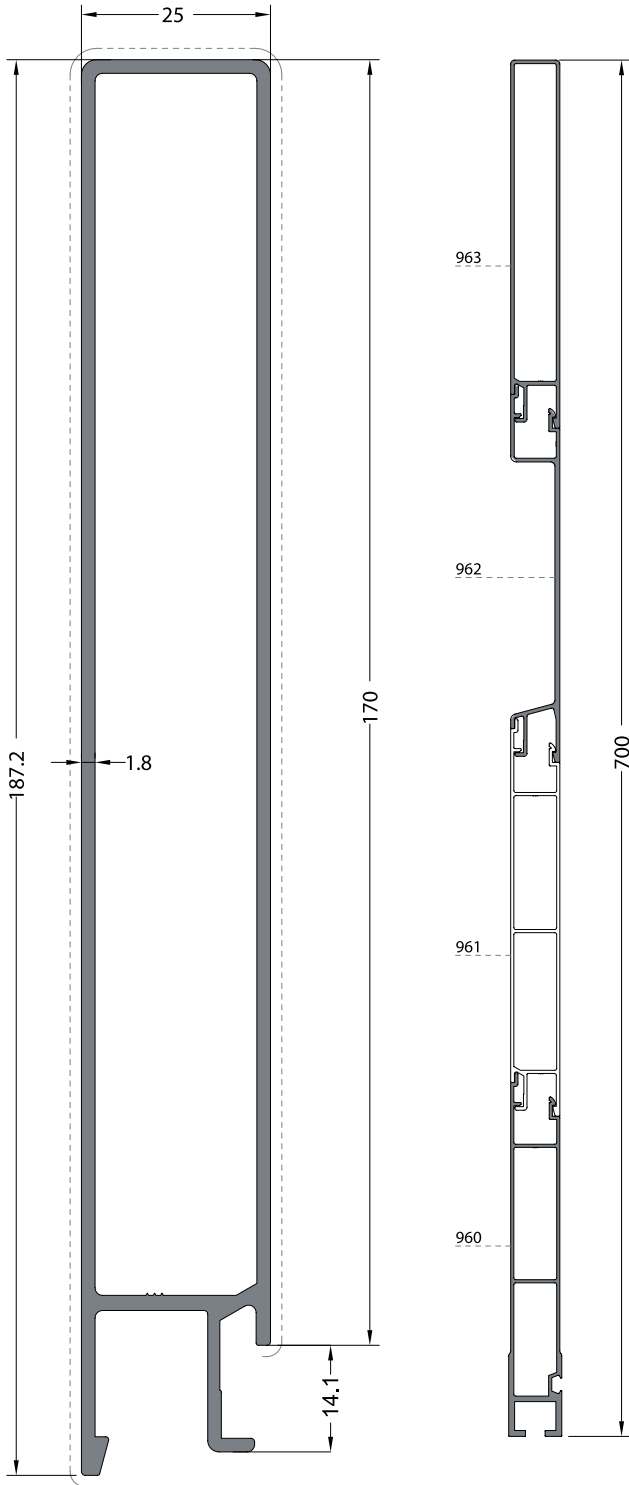

**CODE / KOD**    **THEORETICAL WEIGHT kg/m**  
**963**            *TEORİK AĞIRLIK kg/m*  
**2.090**

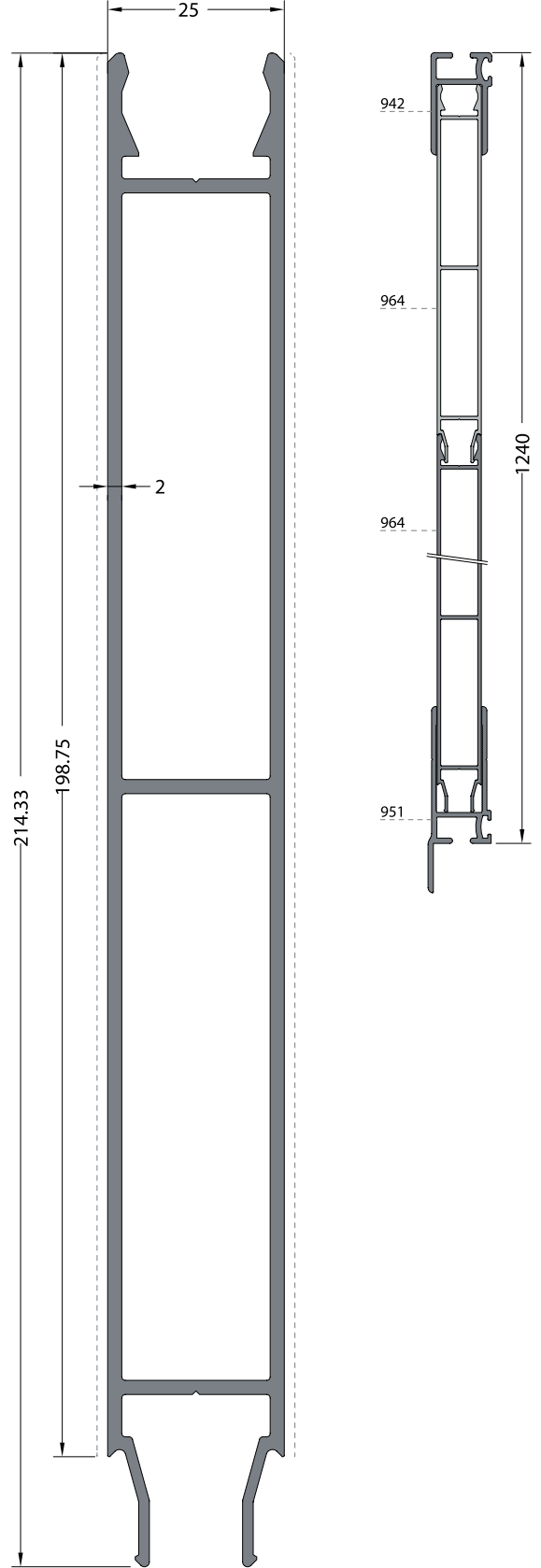

**CODE / KOD**    **THEORETICAL WEIGHT kg/m**  
**964**            *TEORİK AĞIRLIK kg/m*  
**2.693**

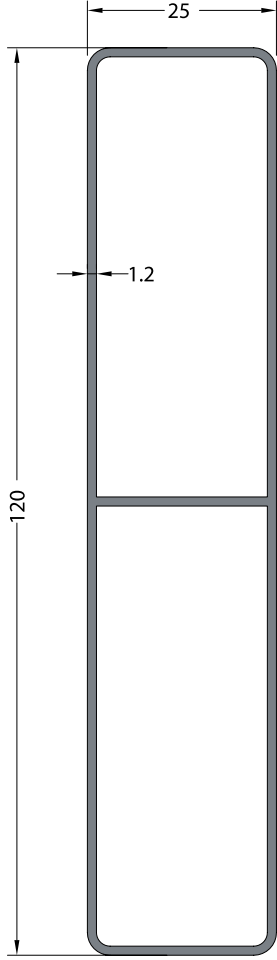

Koruyucu eloksal

CODE / KOD

**965**

**THEORETICAL  
WEIGHT kg/m**

*TEORİK AĞIRLIK kg/m*

**0.988**

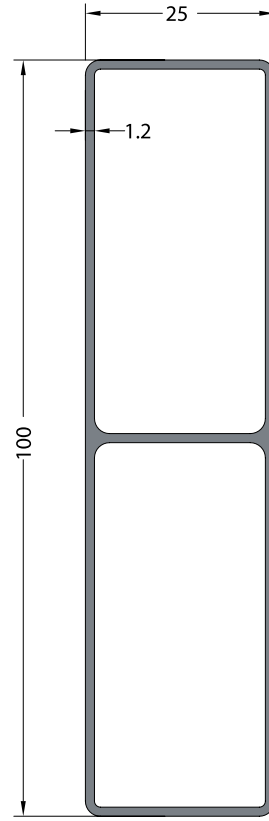

Koruyucu eloksal

CODE / KOD

**966**

**THEORETICAL  
WEIGHT kg/m**

*TEORİK AĞIRLIK kg/m*

**0.872**

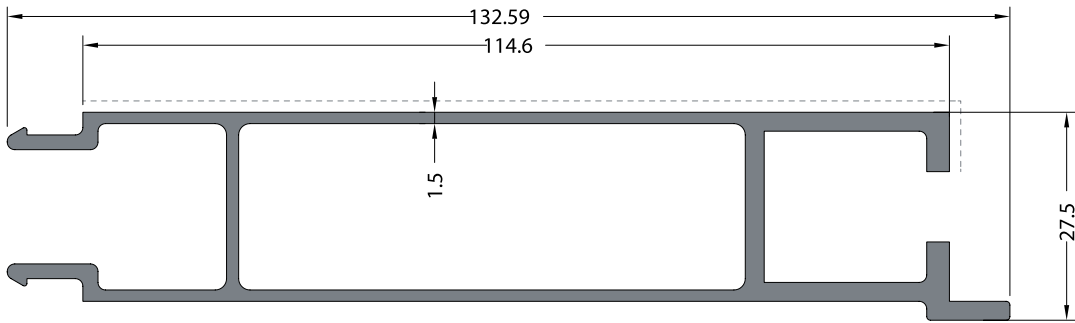
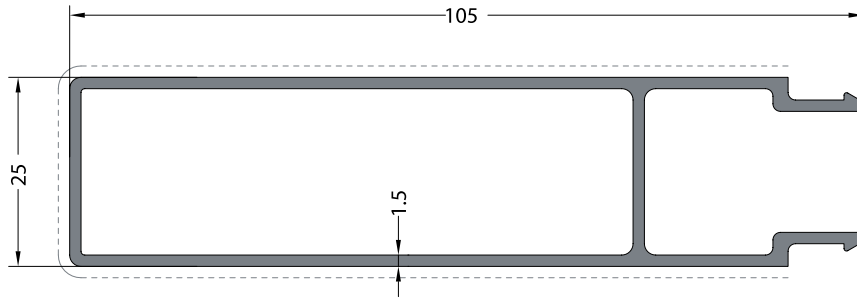
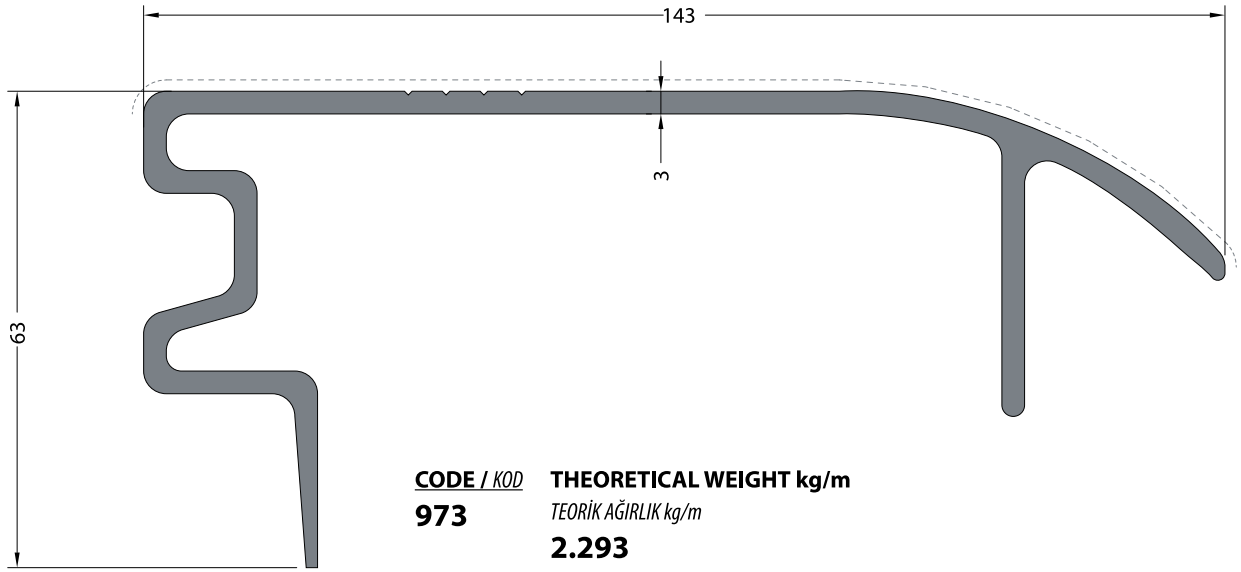

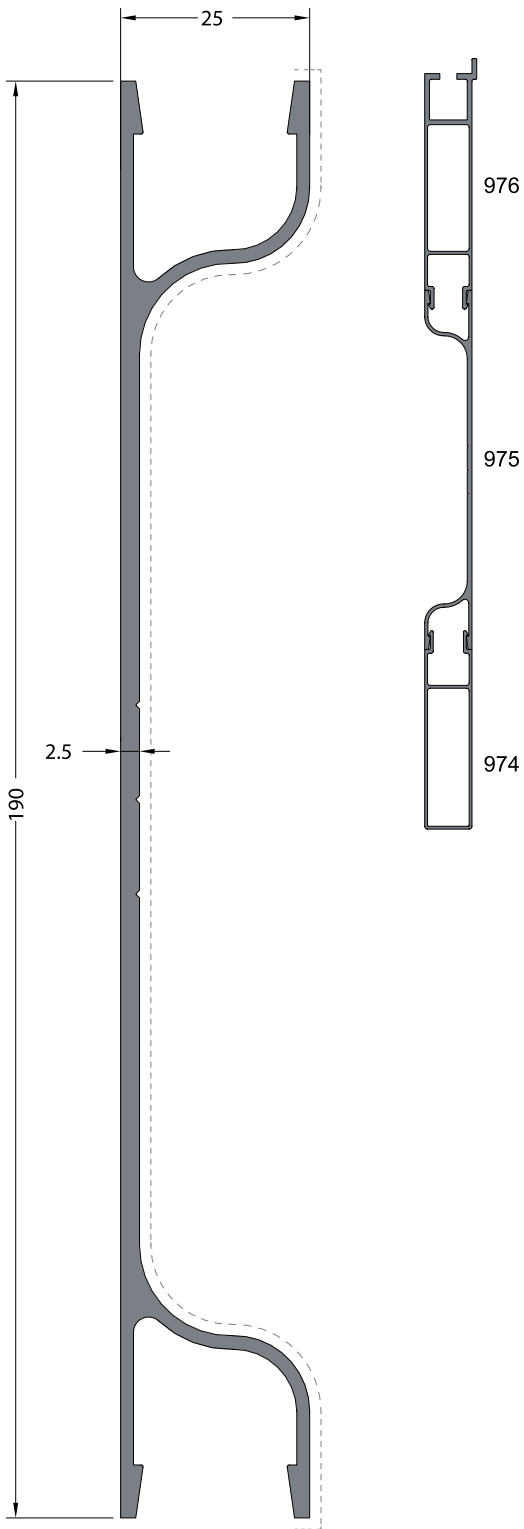

**CODE / KOD**

**975E**

**THEORETICAL WEIGHT kg/m**

*TEORİK AĞIRLIK kg/m*

**1.675**

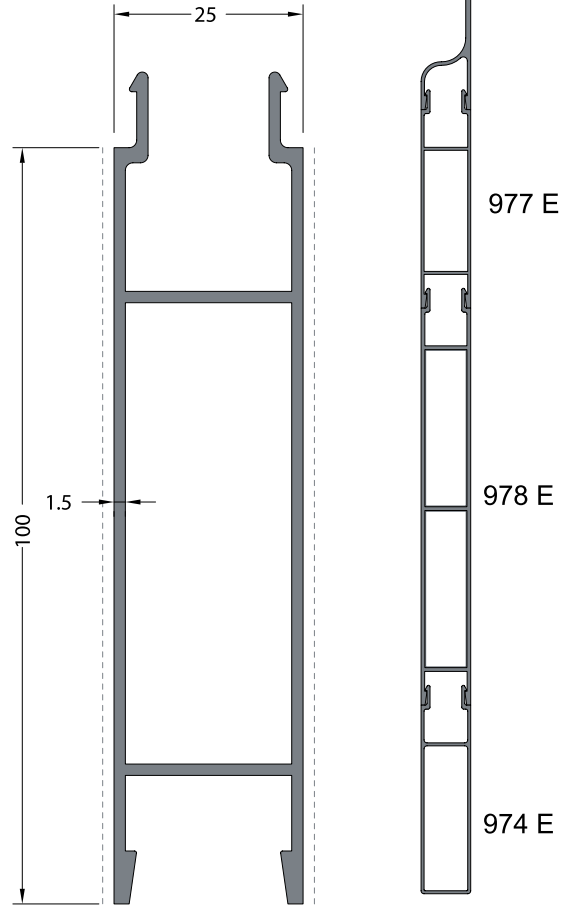

**CODE / KOD**

**977E**

**THEORETICAL WEIGHT kg/m**

*TEORİK AĞIRLIK kg/m*

**1.150**

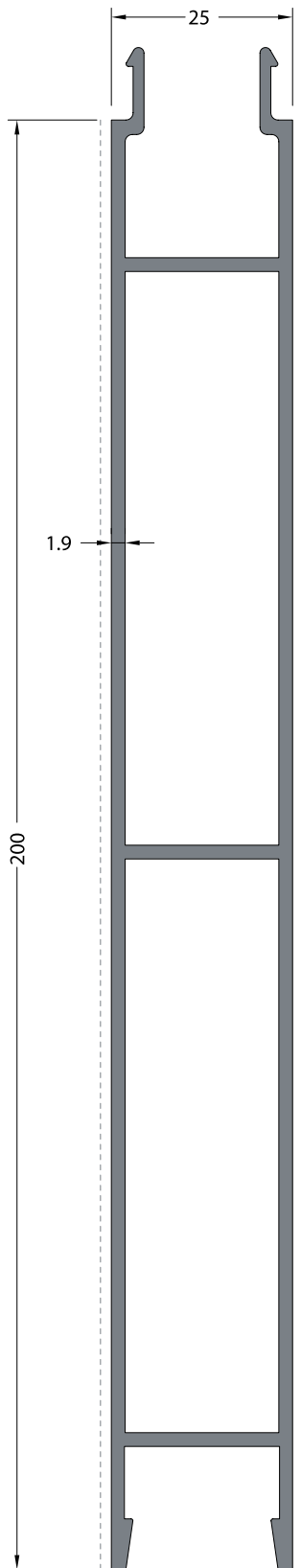

**CODE / KOD**

**978E**

**THEORETICAL WEIGHT kg/m**

*TEORİK AĞIRLIK kg/m*

**2.520**

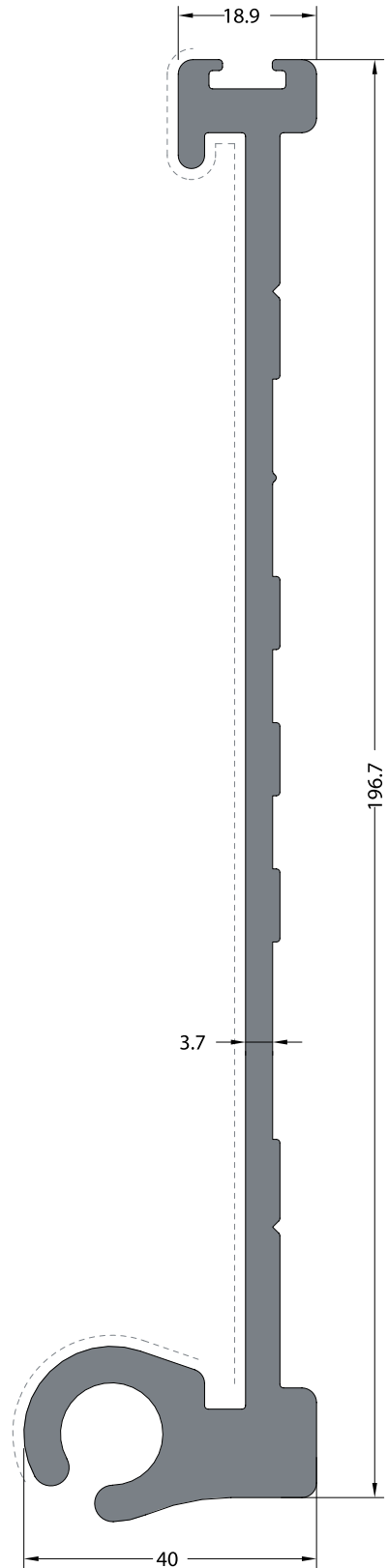
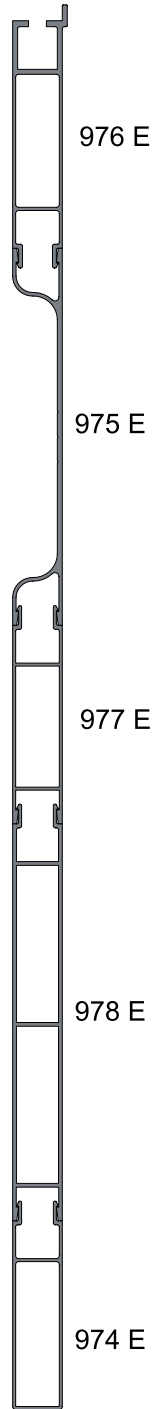

**CODE / KOD**

**988**

**THEORETICAL WEIGHT kg/m**

*TEORİK AĞIRLIK kg/m*

**3.835**



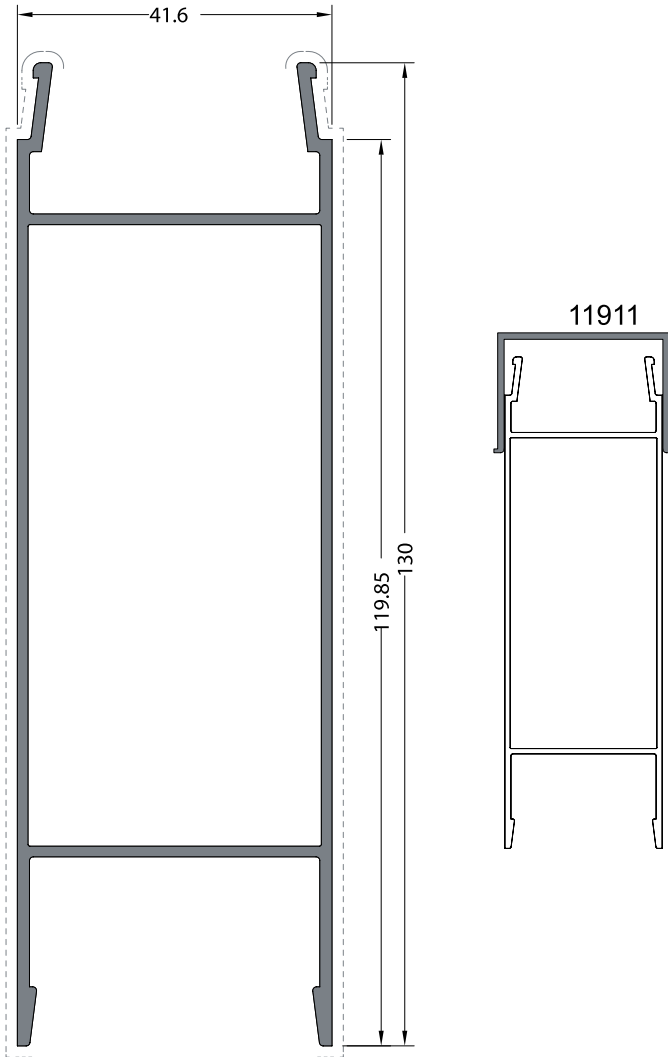

**CODE / KOD**

**994**

**THEORETICAL WEIGHT kg/m**

*TEORİK AĞIRLIK kg/m*

**1.374**

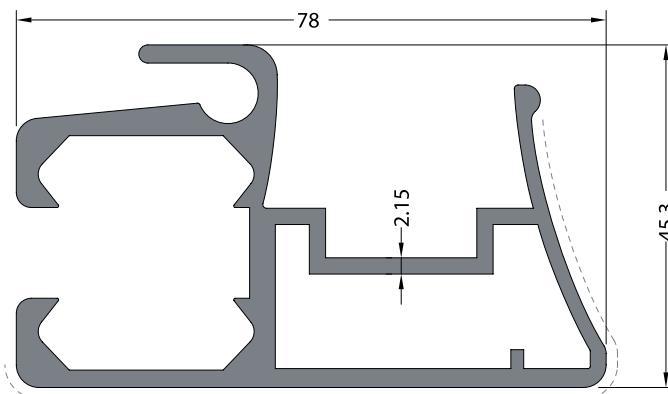

**CODE / KOD**

**989**

**THEORETICAL WEIGHT kg/m**

*TEORİK AĞIRLIK kg/m*

**1.970**

tırprofilleri / truckprofiles

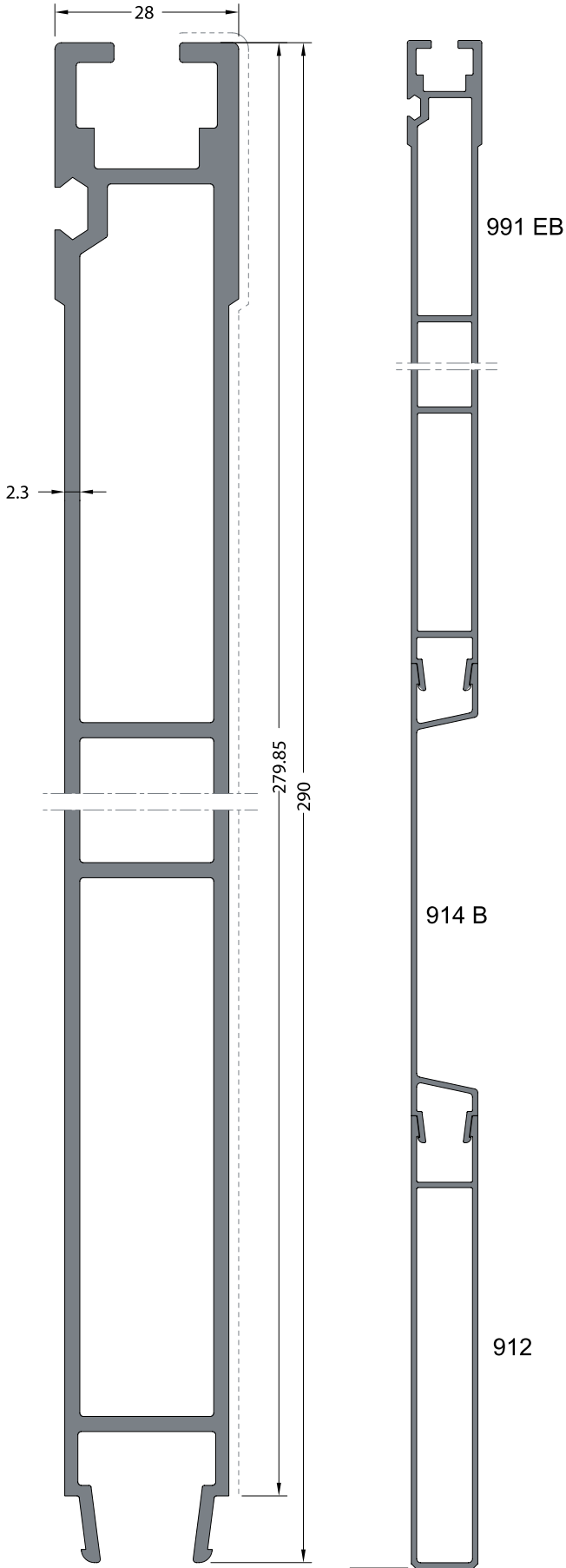

**CODE / KOD**    **THEORETICAL WEIGHT kg/m**  
**991EB**        *TEORİK AĞIRLIK kg/m*  
**4.567**

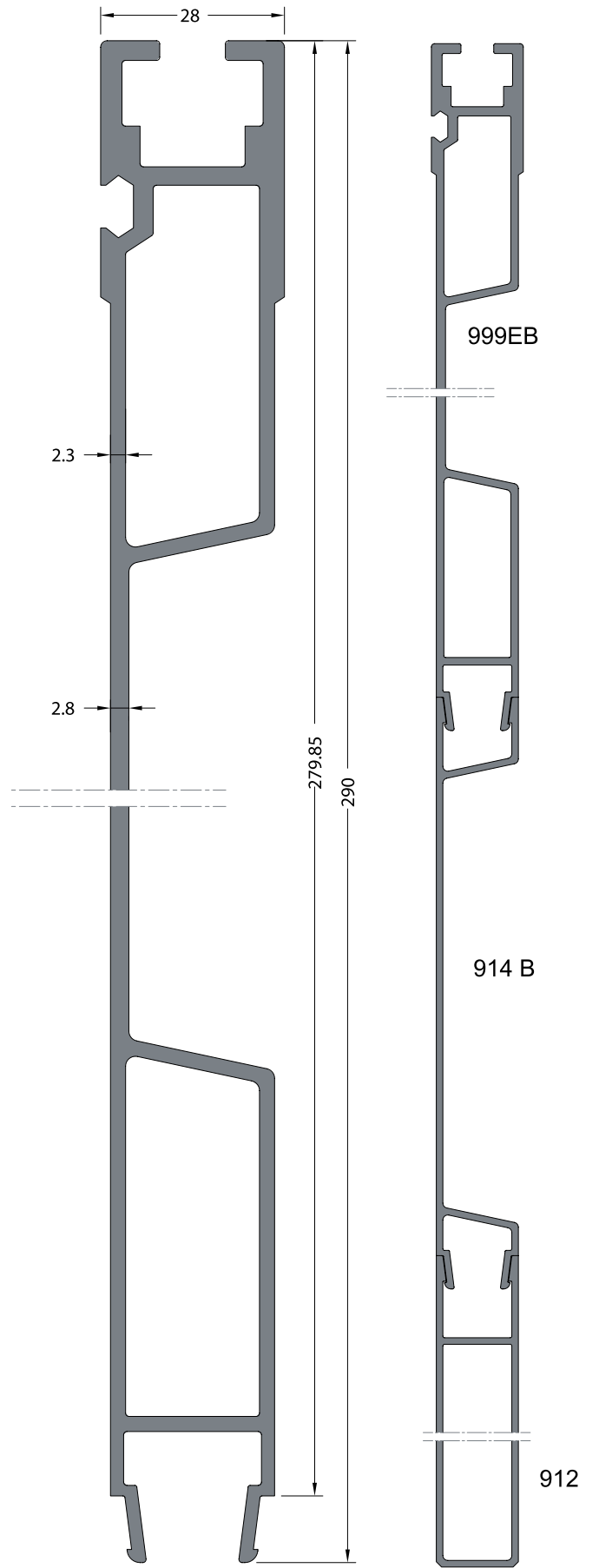

**CODE / KOD**    **THEORETICAL WEIGHT kg/m**  
**999EB**        *TEORİK AĞIRLIK kg/m*  
**3.906**

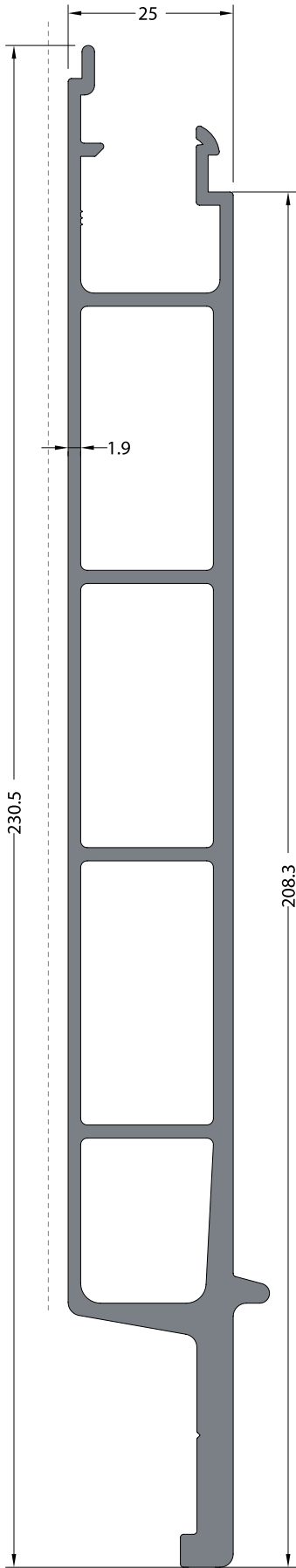

**CODE / KOD**  
**928** **THEORETICAL WEIGHT kg/m**  
TEORİK AĞIRLIK kg/m  
**3.764**

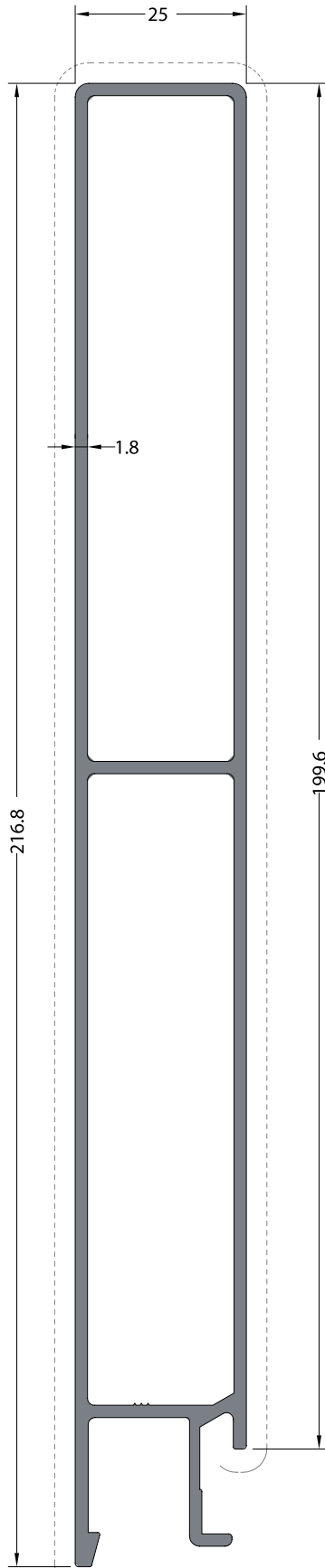

**CODE / KOD**  
**929** **THEORETICAL WEIGHT kg/m**  
TEORİK AĞIRLIK kg/m  
**2.478**

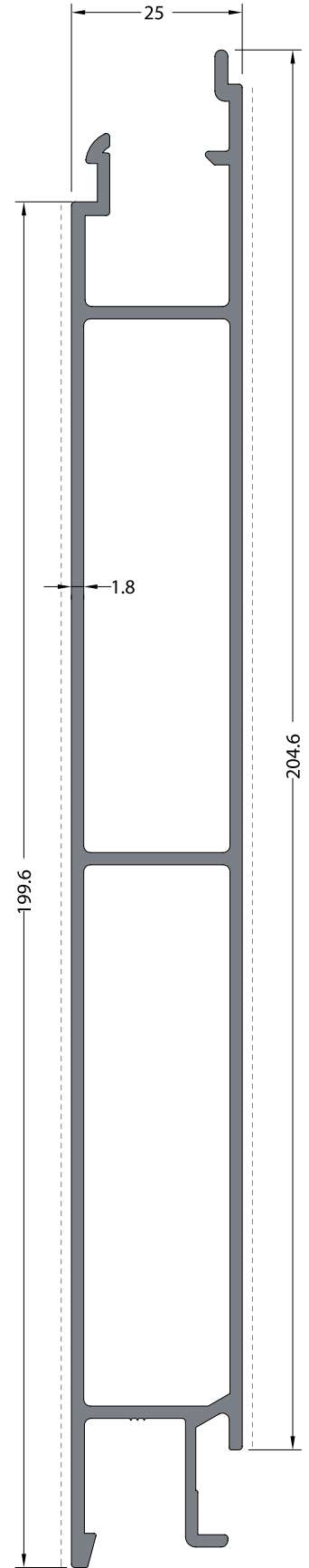

**CODE / KOD**  
**930** **THEORETICAL WEIGHT kg/m**  
TEORİK AĞIRLIK kg/m  
**2.548**

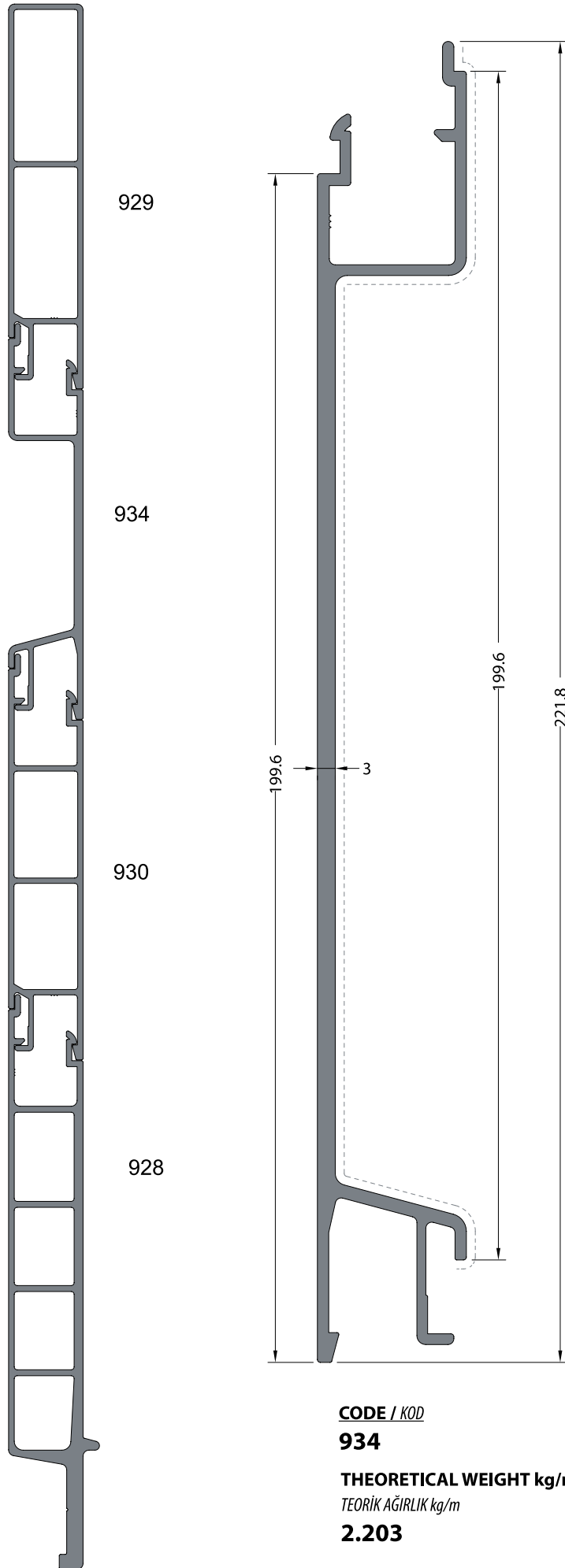

929

934

930

928

199.6

3

199.6

221.8

**CODE / KOD**

**934**

**THEORETICAL WEIGHT kg/m**

**TEORİK AĞIRLIK kg/m**

**2.203**

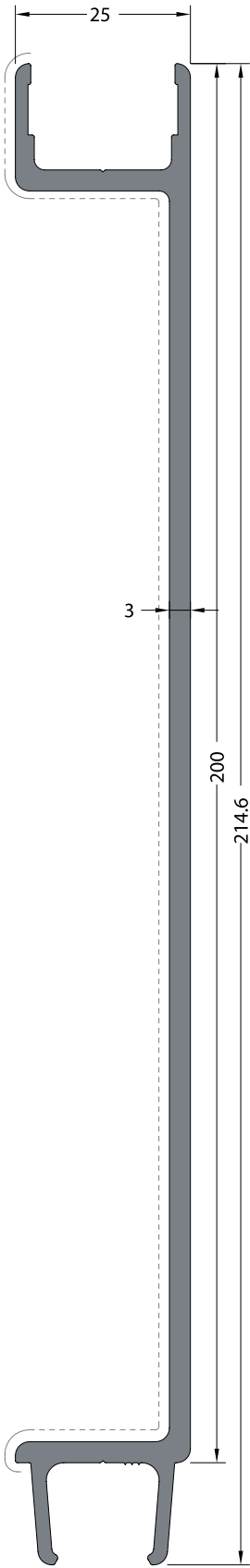

**CODE / KOD**  
**931** **THEORETICAL WEIGHT kg/m**  
TEORİK AĞIRLIK kg/m  
**2.202**

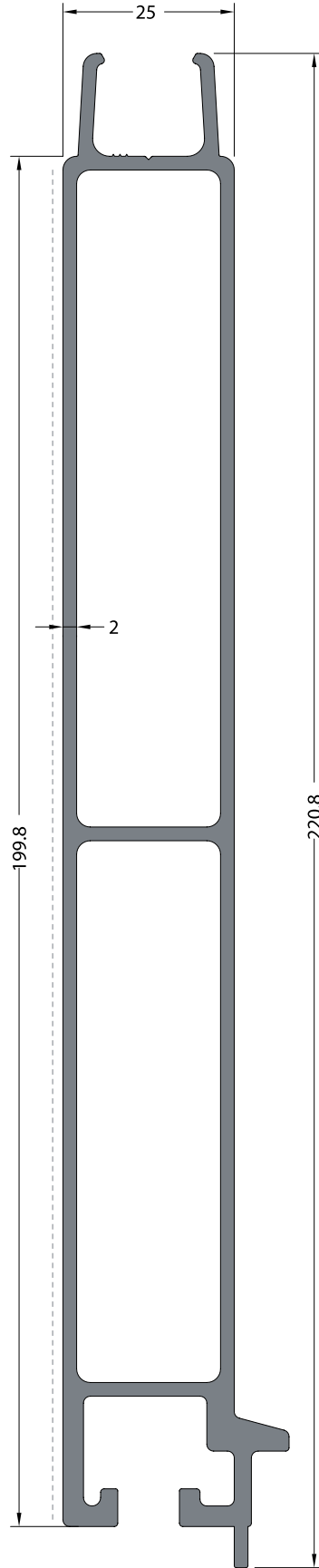

**CODE / KOD**  
**932** **THEORETICAL WEIGHT kg/m**  
TEORİK AĞIRLIK kg/m  
**1.033**

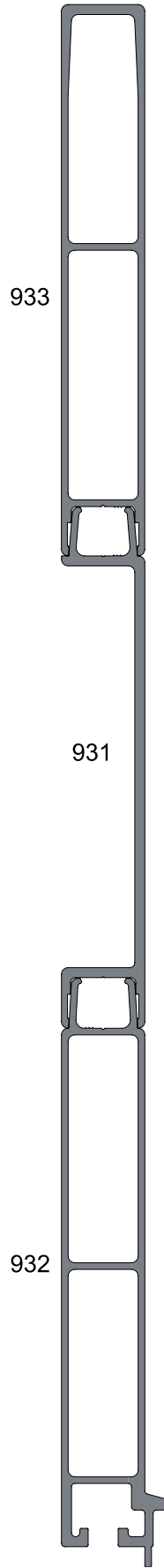

**CODE / KOD**  
**933** **THEORETICAL WEIGHT kg/m**  
TEORİK AĞIRLIK kg/m  
**3.069**

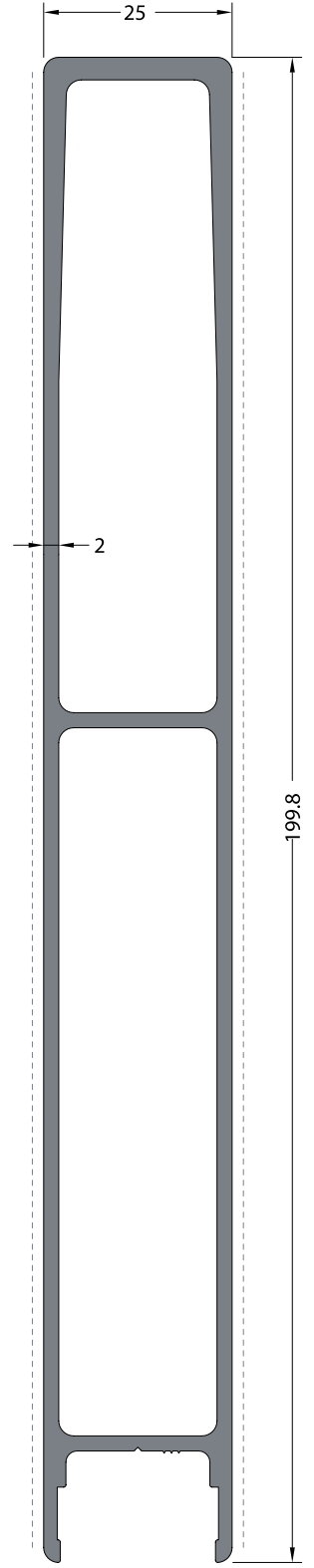

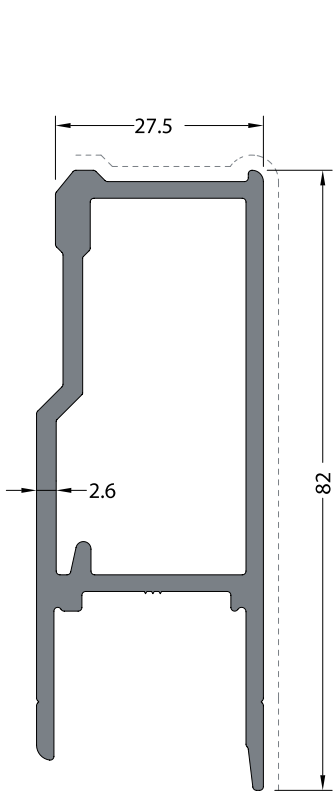

**CODE / KOD**

**935**

**THEORETICAL  
WEIGHT kg/m**

*TEORİK AĞIRLIK kg/m*

**1.429**

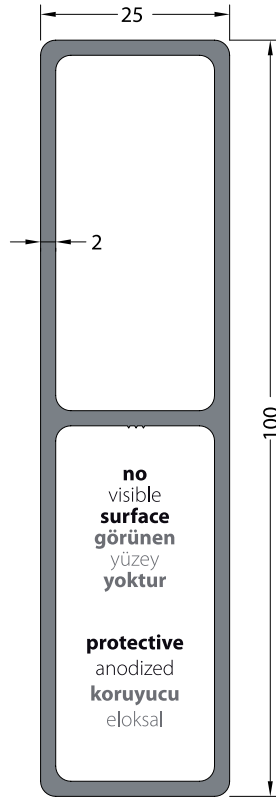

**CODE / KOD**

**936**

**THEORETICAL  
WEIGHT kg/m**

*TEORİK AĞIRLIK kg/m*

**1.435**

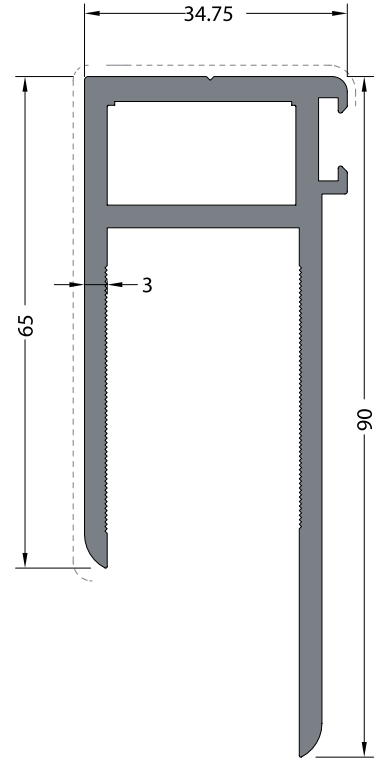

**CODE / KOD**

**982**

**THEORETICAL  
WEIGHT kg/m**

*TEORİK AĞIRLIK kg/m*

**1.701**

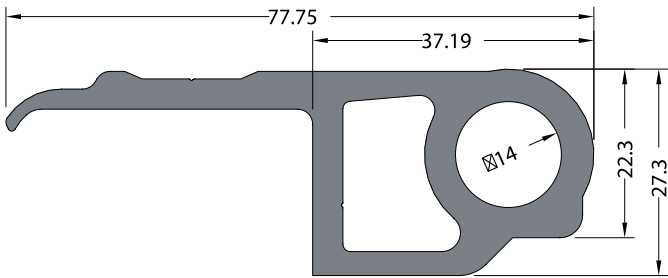

**no visible surface  
görünen yüzey yoktur**

**CODE / KOD**

**985**

**THEORETICAL  
WEIGHT kg/m**

*TEORİK AĞIRLIK kg/m*

**1.769**

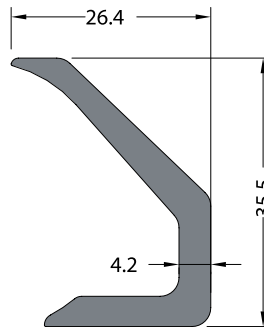

**no visible surface  
görünen yüzey yoktur**

**CODE / KOD**

**986**

**THEORETICAL  
WEIGHT kg/m**

*TEORİK AĞIRLIK kg/m*

**0.671**

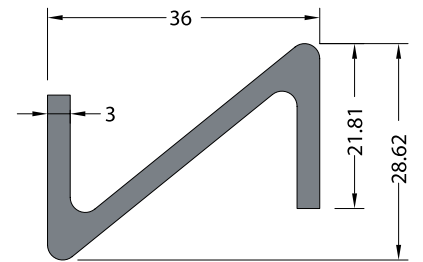

**no visible surface  
görünen yüzey yoktur**

**CODE / KOD**

**987**

**THEORETICAL  
WEIGHT kg/m**

*TEORİK AĞIRLIK kg/m*

**0.684**

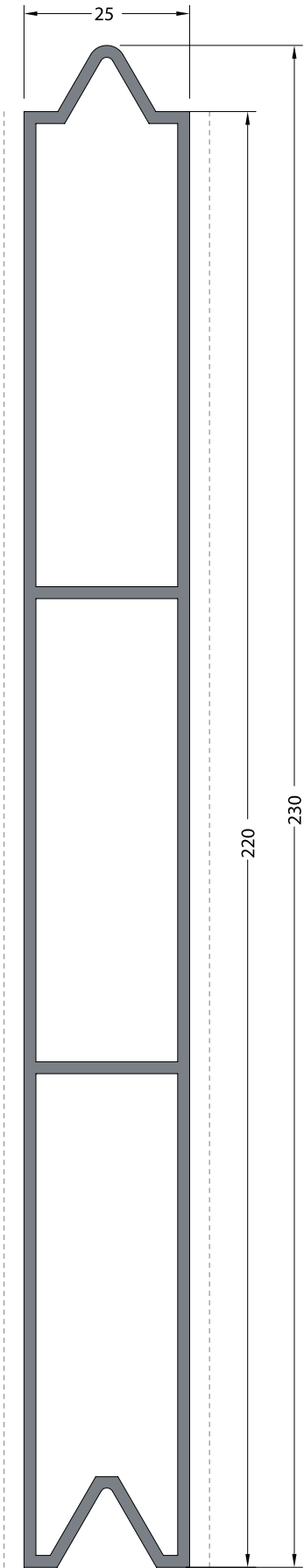

**CODE / KOD** THEORETICAL WEIGHT kg/m  
**990** TEORİK AĞIRLIK kg/m  
**2.685**

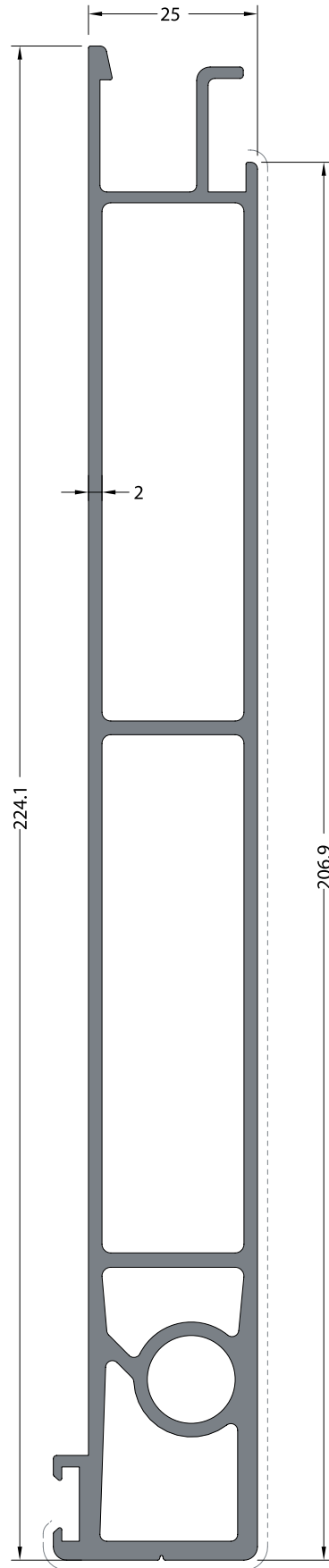

**CODE / KOD** THEORETICAL WEIGHT kg/m  
**968** TEORİK AĞIRLIK kg/m  
**3.427**

969

968

tırprofilleri / truckprofiles

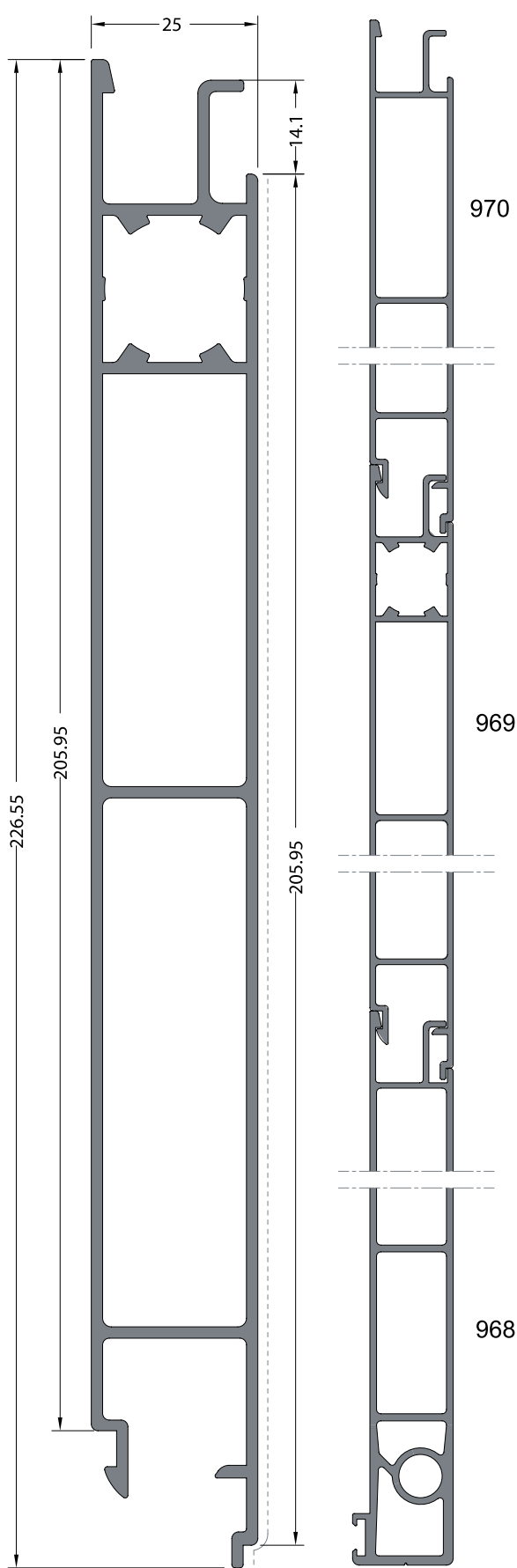

**CODE / KOD** THEORETICAL WEIGHT kg/m  
**969** TEORİK AĞIRLIK kg/m  
**2.653**

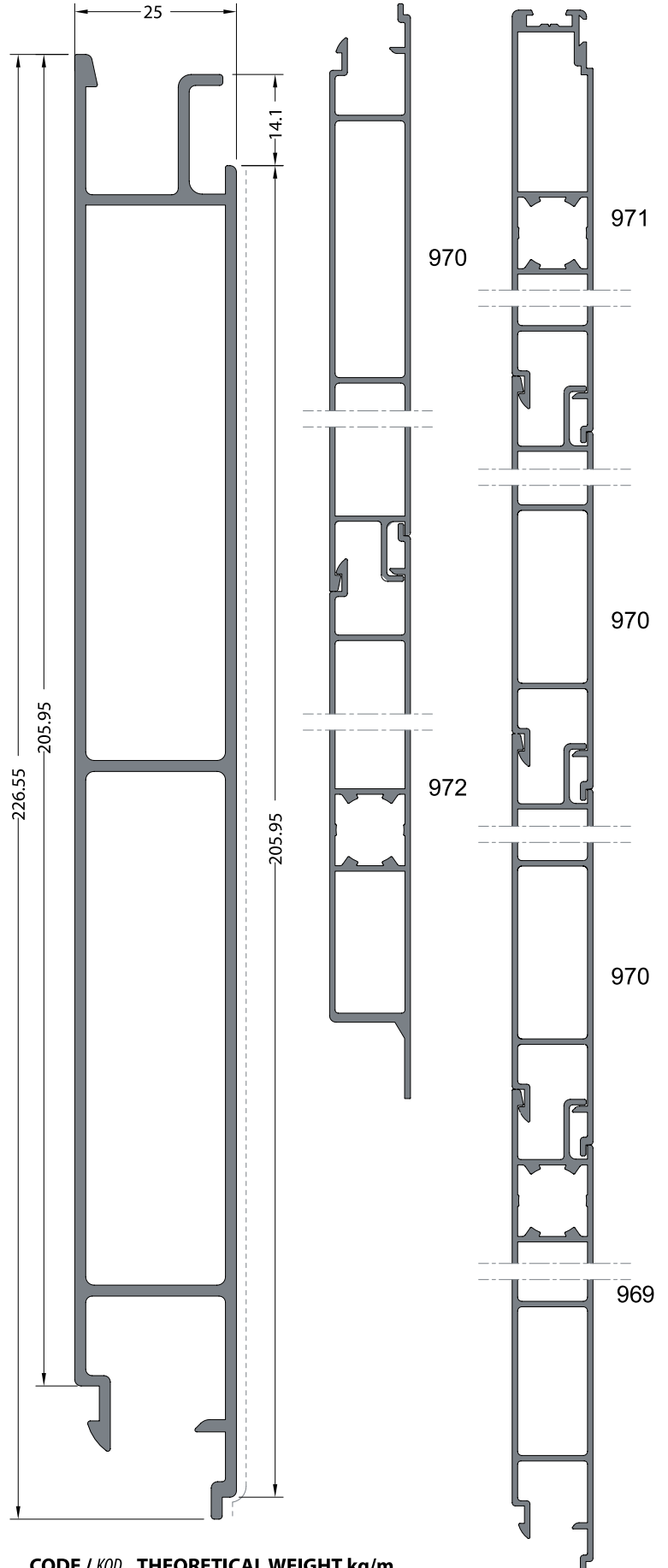

**CODE / KOD** THEORETICAL WEIGHT kg/m  
**970** TEORİK AĞIRLIK kg/m  
**2.449**



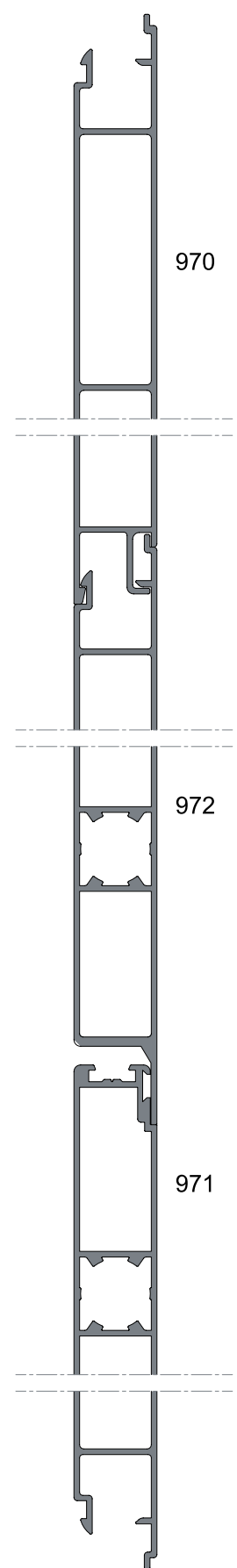
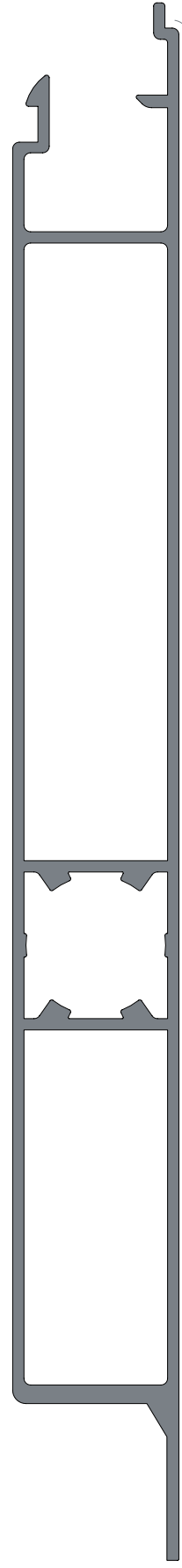
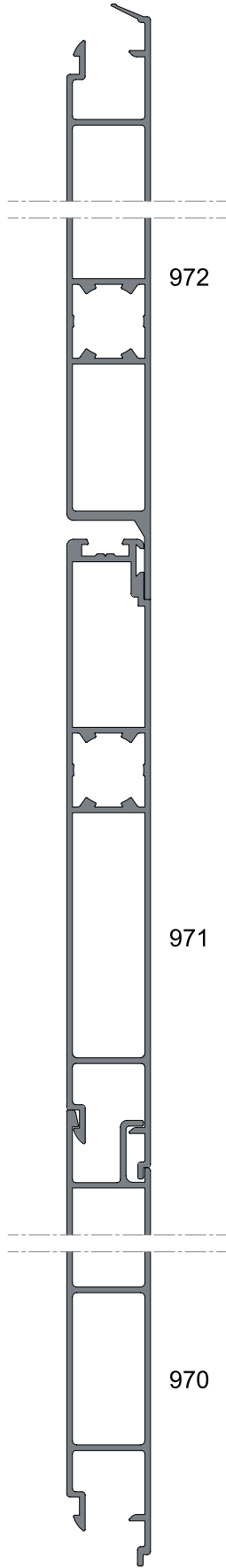

**CODE / KOD** THEORETICAL WEIGHT kg/m  
**971** TEORİK AĞIRLIK kg/m  
**2.561**

**CODE / KOD** THEORETICAL WEIGHT kg/m  
**972** TEORİK AĞIRLIK kg/m  
**2.650**

Produced by 

**KURTOĞLU BAKIR KURŞUN SAN. A.Ş.**

Hacıseremet Mevkii, Tem Çorlu Çıkışı Velimeşe 59880 Pk 323 Tekirdağ / TÜRKİYE

T: +90 282 684 70 00 F: +90 282 684 70 01

www.kurtogluas.com kurtoglu@kurtogluas.com

 **Lorenzoline**<sup>®</sup>  
aluminum profile system